

STORMVAULT DIVERTER MANHOLE MODEL: SVDMMH-96

MANHOLE DATA :

DIVERTED STORMWATER QUALITY DESIGN FLOW (SQDF)	XX.XX-CFS (XXX-GPM)
MANHOLE INTERNAL DIAMETER INCHES (Ø)	96"
RIM ELEVATION (FT)	XXX.XX'

PIPE DATA	DIAMETER (Ø)	MATERIAL	INV. EL.	ORIENTATION
INLET PIPE	XX"	PVC/HDPE/RCP	XXXX.XX' ±	XXX°
WATER QUALITY FLOW OUTLET PIPE	XX"	PVC/HDPE/RCP	XXXX.XX' ±	XXX°
OUTLET PIPE	XX"	PVC/HDPE/RCP	XXXX.XX' ±	XXX°

ADJUSTABLE WEIR ELEVATIONS AND HEIGHTS :

A	WEIR CREST ELEVATION	XX.XX'
B	WEIR HEIGHT (ABOVE INLET INVERT)	XX.XX'
C	WEIR WALL ELEVATION	XX.XX'
D	WEIR WALL HEIGHT ABOVE PIPE INVERT	XX.XX'
E	FLOOR ELEVATION	XX.XX'
F	WEIR WALL TOTAL HEIGHT	XX.XX'
G	HEIGHT TO BOTTOM OF ADJUSTABLE WEIR OPENING (ADJUSTMENT HEIGHT)	XX.XX'
H	WEIR ORIENTATION (45° TYP.)	XXX°

(*) WEIR HEIGHT DIMENSION DETERMINED BY DESIGN ENGINEER'S HYDRAULIC ANALYSIS

PIPE AND WEIR ORIENTATION KEY:

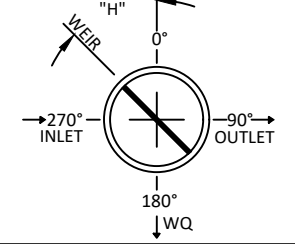

NOTES/SPECIAL REQUIREMENTS:

GENERAL NOTES :

- THIS LAYOUT SKETCH IS PROVIDED IN A SCHEMATIC FORMAT. THIS SHEET IS IN ENGINEERING & CONSTRUCTION FORMATTED DETAIL. ENGINEERING & CONSTRUCTION DETAIL READILY AVAILABLE. CONTACT JENSEN PRECAST.
- PLAN VIEW FRAME AND COVER NOT SHOWN FOR CLARITY.
- 66" DIAMETER RCP/HDPE IS THE LARGEST SUGGESTED INLET/OUTLET PIPE SIZE FOR THIS DIVERSION STRUCTURE.
- INLET/OUTLET PIPE STUBS PROVIDED BY JENSEN PRECAST, PIPE TYPE ADAPTERS PROVIDED BY CUSTOMER.
- DESIGN LOAD: H-20 TRAFFIC FROM 1' TO 6' OF COVER PER ASTM C890 & C915 AND ASSHTO LOADING METHODS.
- CONTACT JENSEN PRECAST FOR OTHER INSTALLATION DEPTHS, INLET/OUTLET CONFIGURATIONS, AND/OR LOADING CONDITIONS FOR STRUCTURAL DESIGN REVISION TO MEET PROJECT SPECIFIC NEEDS.

CONSTRUCTION NOTES :

- CONTRACTOR TO VERIFY VERTICAL DIMENSIONS OF ALL PRECAST PIECES IN FIELD.
- VERIFY SUBBASE ELEVATION BEFORE PLACING PRECAST COMPONENTS OR BACKFILLING.
- APPLY BUTYL MASTIC AND/OR GROUT TO SEAL JOINTS OF STRUCTURE.
- CONTRACTOR TO GROUT ALL PIPE PENETRATIONS IN FIELD AS NECESSARY.
- CONTRACTOR TO ADJUST FRAME/COVER ELEVATION IN FIELD AS NECESSARY.
- ALL INTERNAL COMPONENTS INSTALLED BY MANUFACTURER.

MATERIALS :

- ALL DIMENSIONS ARE IN FEET OR DECIMAL INCHES
- PRECAST MATERIALS AND MANUFACTURING METHODS SHALL CONFORM TO ASTM C-857 & C-478.
- CONCRETE SHALL HAVE A MINIMUM COMPRESSIVE STRENGTH F'c = 3,000-PSI AT 28-DAYS.
- THE PORTLAND CEMENT USED IN THE PRECAST SECTION SHALL MEET THE REQUIREMENTS OF TYPE II/V HIGH SULFATE RESISTANT CEMENT IN ACCORDANCE WITH ASTM CLASS M C-150.

LIFTING WEIGHTS :

- HEAVIEST PICK WEIGHT IS 22,500-LBS.
- JENSEN CRANE TRUCK CAN SET A MAXIMUM OF 25,000-LBS AT 15-FT OFFSET DISTANCE FROM CENTER OF CRANE TRUNNION.

[] REGIONAL MANUFACTURING DIFFERENCE :**

THESE ARE TEMPLATE DRAWINGS. JOINTS, WALL, TOP AND BOTTOM SLAB THICKNESS VARY ACROSS JENSEN'S REGIONAL MANUFACTURING FACILITIES AND ALSO FOR SITE SPECIFIC LOADING CONDITIONS. CONFIRM FINAL THICKNESS, PIPING CONFIGURATION AND CONCRETE THICKNESS PER CONSTRUCTION SUBMITTAL DRAWINGS. ADJUST FINAL DIMENSIONS TO EXTERIOR INVERT AND SUBGRADE ELEVATION PER REGIONAL DIFFERENCES.

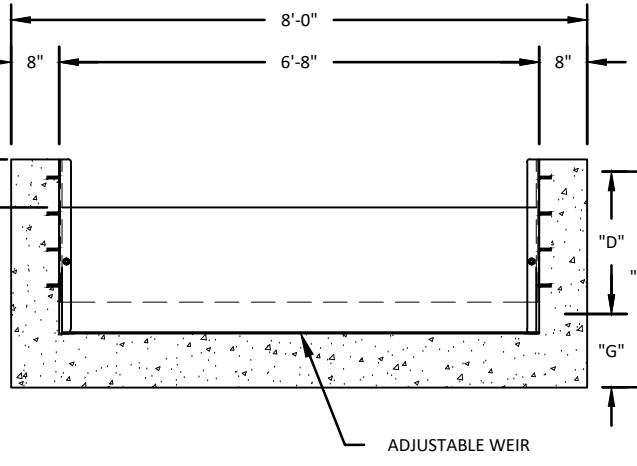
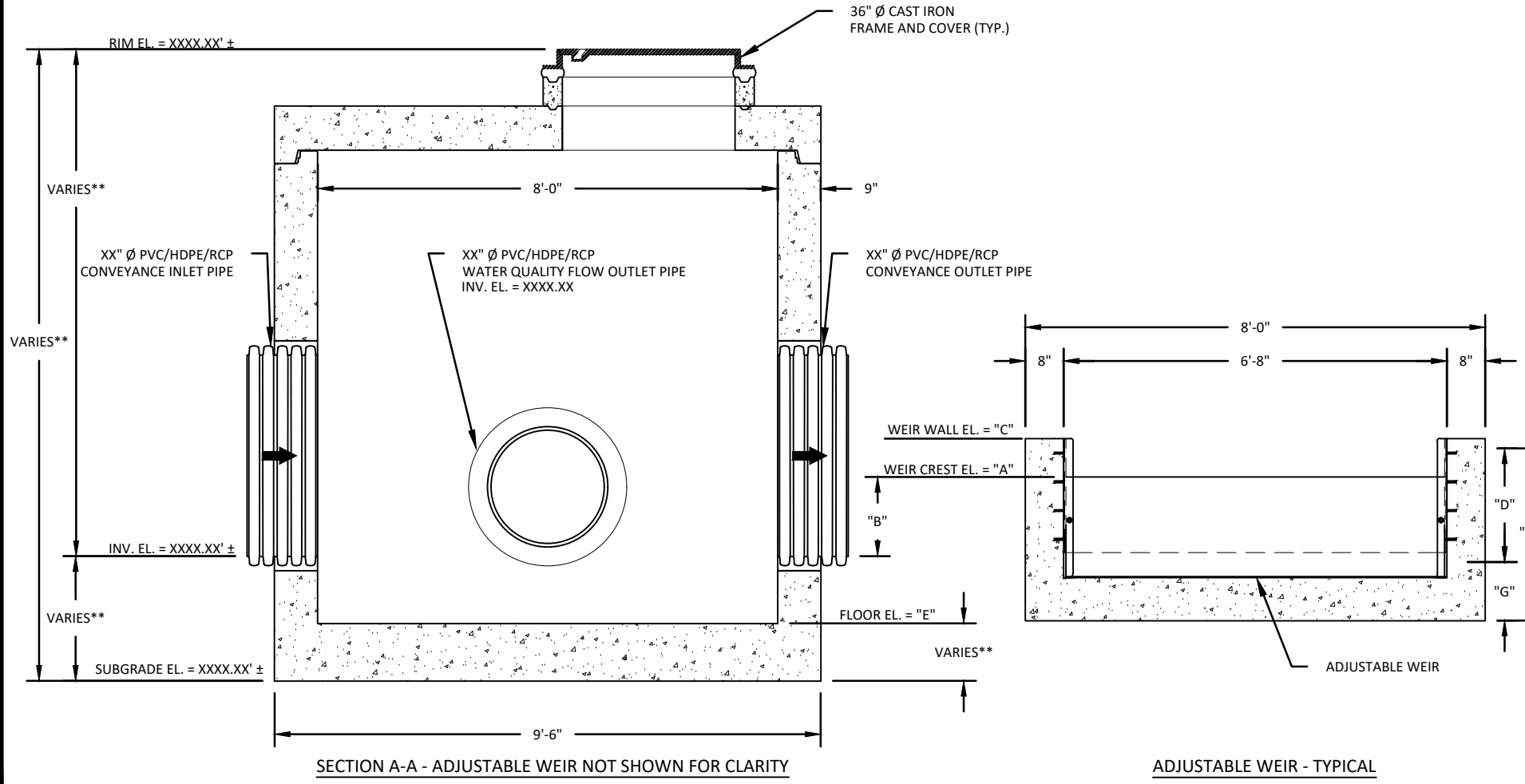
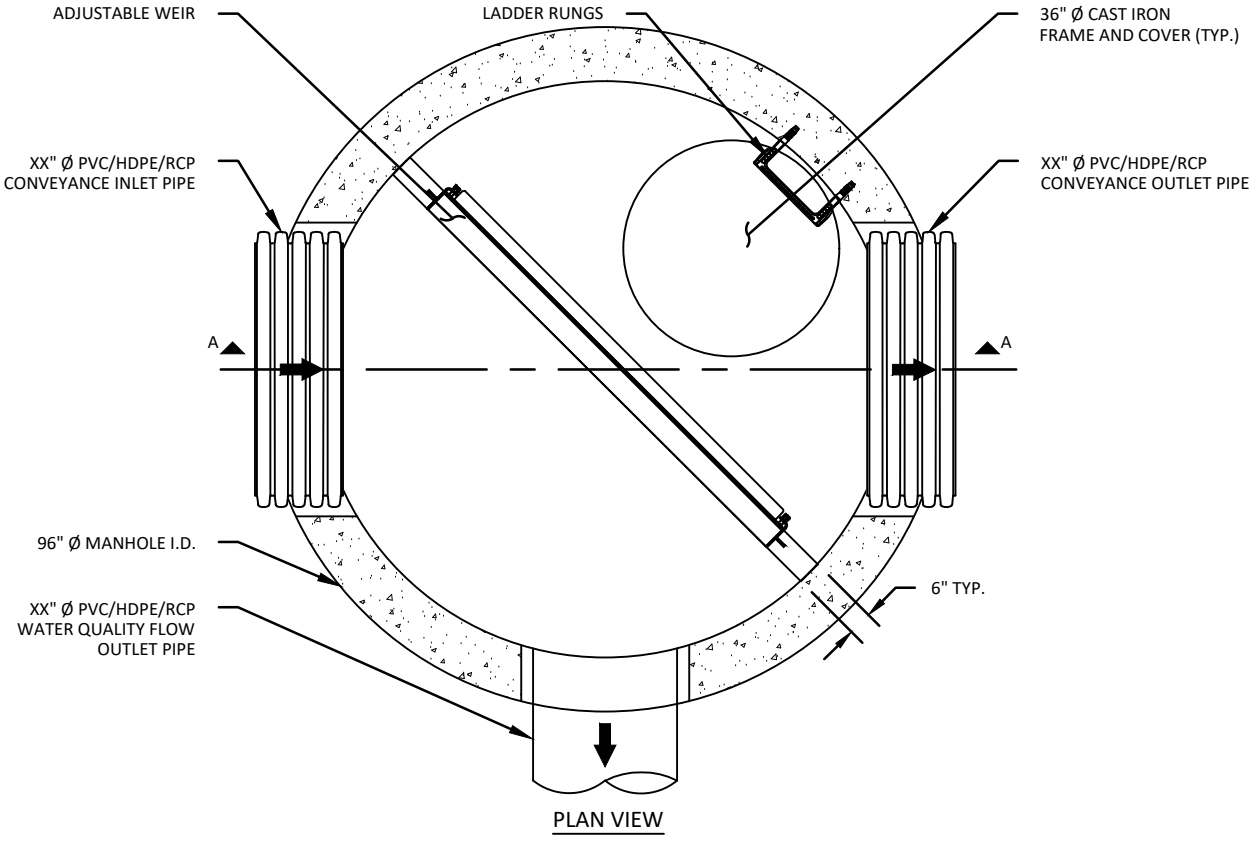

SECTION A-A - ADJUSTABLE WEIR NOT SHOWN FOR CLARITY

ADJUSTABLE WEIR - TYPICAL

SCALE: 1" = 32"

MODEL: SVDMH-96 STORMVAULT DIVERTER MANHOLE	PROJECT: PROJECT NAME CITY, STATE		521 DUNN CIRCLE, SPARKS, NV 89431-6312 (877) 649-0095 FAX (775) 440-2013
	ORG. DWG. DATE XX/XX/XXXX	SCALE: AS SHOWN	
DRAWN BY X.XXXX		SHEET NUMBER SVDMH-96	

Copyright Information © 2011 Jensen Precast All Rights Reserved. All materials appearing as Jensen Precast documents and the like are proprietary work product and are protected under U.S. copyright and other laws. Unless in conjunction with business conducted with Jensen Precast, any use of Jensen Precast work product without express, written consent is prohibited and recipient is prohibited from distributing any and all work product to non-approved third parties under penalty of civil action.