

MODEL JPHV-28000
JENSEN PRECAST HIGH VELOCITY INTERCEPTOR
HORIZONTAL FLOW CLARIFIER

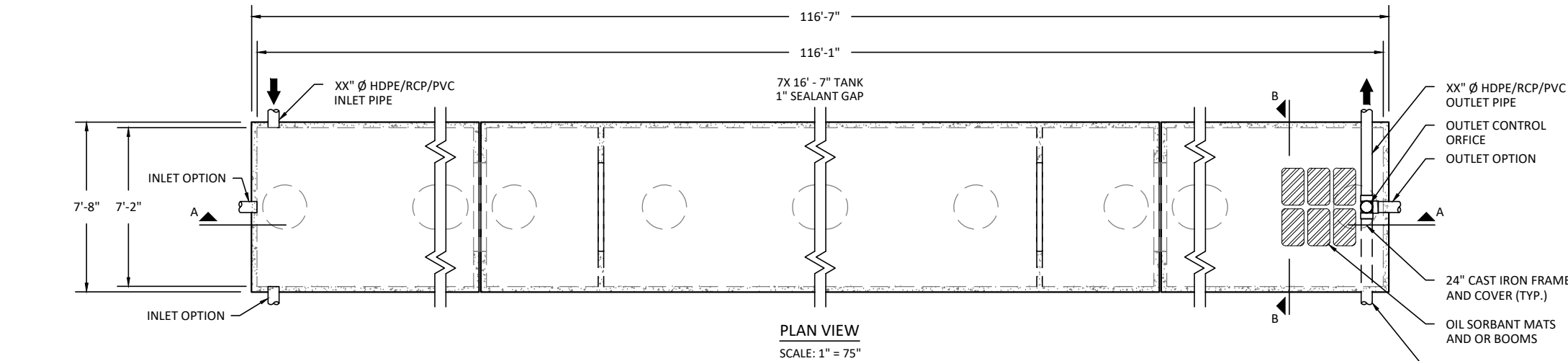

PLAN VIEW
 SCALE: 1" = 75"

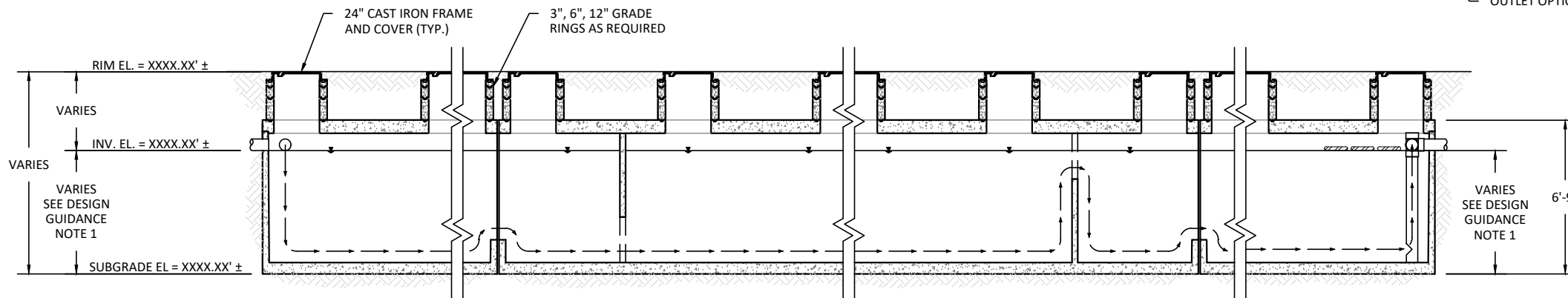

SECTION A-A
 SCALE: 1" = 75"

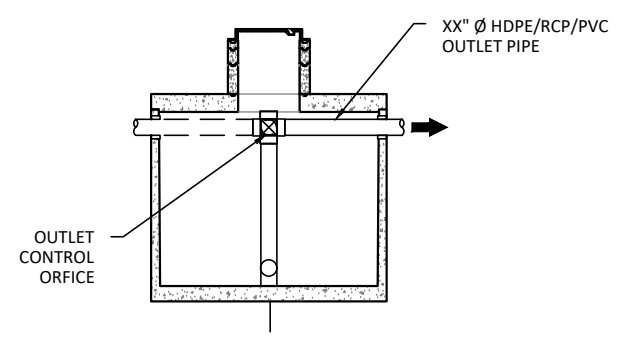
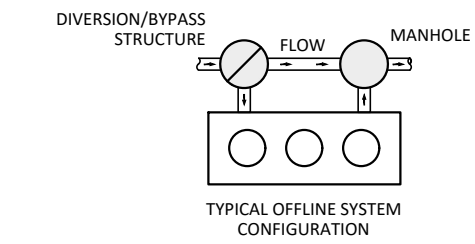

SECTION B-B
 SCALE: 1" = 75"

HYDRAULICS AND TREATMENT :

OPTIMUM STORMWATER QUALITY DESIGN FLOW (SQDF)	7.50-CFS
STORM DRAIN DESIGN CONVEYANCE FLOW	X.XX-CFS
RETURN FREQUENCY/PERIOD OF PEEK DESIGN CONVEYANCE FLOW	XX-YRS

TREATMENT PERFORMANCE NOTES :

- THIS STORMWATER QUALITY DESIGN FLOW (SQDF) RATE CORRESPONDS TO A 6-GPM/FT² SURFACE LOADING RATE, TARGETING THE REMOVAL OF THE 60-MICRON, FINE SILT SIZE PARTICLE FROM STORMWATER RUNOFF.
- THIS 6-GPM/FT² SURFACE LOADING RATE OF THE SQDF IS FOUR (4X) TIMES MORE CONSERVATIVE THAN THE MAXIMUM ALLOWABLE VALUE OF 24-GPM/FT² FOR HYDRODYNAMIC SEPARATORS. THIS ENSURES REMOVAL EFFICIENCY AS WELL AS A SAFETY FACTOR ENABLING TREATMENT OF LARGER STORM EVENTS. THE 24-GPM/FT² MAXIMUM SIZING GUIDANCE IS EXPLICITLY SET FORTH IN SECTION MP-51 OF THE BEST MANAGEMENT PRACTICE HANDBOOK, NEW DEVELOPMENT AND REDEVELOPMENT ADOPTED BY THE NINE (9) REGIONAL BOARDS OF THE CALIFORNIA REGIONAL WATER QUALITY CONTROL BOARD. THIS HANDBOOK IS PUBLISHED BY THE CALIFORNIA STORMWATER QUALITY ASSOCIATION (CASQA).
- AT ALL FLOW RATES LESS THAN OR EQUAL TO THE SQDF LISTED IN THE TABLE, THIS JPHV PROVIDES:
 - FLOATING DEBRIS RETENTION
 - SEDIMENTATION WITH SCOUR PROTECTION
 - OIL & GREASE ABSORPTION
 - ORIFICE OUTLET FLOW CONTROL

DESIGN GUIDANCE NOTES :

- THE IDEAL VERTICAL PLACEMENT OF THE INLET AND OUTLET PIPES OF A JPHV HORIZONTAL FLOW CLARIFIER MAXIMIZES THE USE OF AS MUCH THE TANK'S DEAD POOL VOLUME AS POSSIBLE. TO ACHIEVE THIS, PLACE TOP EXTERIOR OF THE INLET PIPE APPROXIMATELY 3-INCHES BELOW THE SOFFIT OF THE TOP SLAB. ESTABLISH THE INLET INVERT ELEVATION AFTER THIS PLACEMENT. SET THE DISCHARGE OUTLET PIPE INVERT APPROXIMATELY 2-INCHES BELOW THE INLET INVERT. THIS IS A BEST DESIGN GUIDELINE PRACTICE. SETTING THE INLET PIPE INVERT MORE THAN 3" BELOW THE SOFFIT IS ACCEPTABLE, THOUGH THE TANK DEAD POOL VOLUME WILL NOT BE MAXIMIZED.
- A STANDARD JENSEN PRECAST INTERNAL FLOW CONTROL ORIFICE PLATE RESTRICTS OUTLET FLOW TO THE SQDF RATE AND THEREBY ACCUMULATED FLOATABLES AND FINE SEDIMENTS ARE RETAINED DURING LARGER STORM EVENTS.
- AN OFFLINE JPHV CONFIGURATION WITH INTERNAL ORIFICE FLOW CONTROL IS RECOMMENDED DEPLOYMENT PRACTICE.

GENERAL NOTES :

- THIS LAYOUT SKETCH IS PROVIDED IN A SCHEMATIC FORMAT. DETAIL OF JENSEN DIVERSION MANHOLE/BYPASS STRUCTURE WITH ADJUSTABLE WEIR AND OPTION FORMED BASE CHANNELS NOT SHOWN. THIS SHEET IS IN ENGINEERING & CONSTRUCTION FORMATTED DETAIL. ENGINEERING & CONSTRUCTION DETAIL READILY AVAILABLE. CONTACT JENSEN PRECAST.
- PLAN VIEW TOP SLAB WITH FRAMES AND COVERS ARE NOT SHOWN FOR CLARITY.
- INLET/OUTLET PIPE STUBS PROVIDED BY JENSEN PRECAST, PIPE TYPE ADAPTORS PROVIDED BY CUSTOMER.
- OIL SORBENT MATS TO BE EQUIPPED WITH RETAINING CORD AND RING, SECURED TO OR UNDER FRAME AND COVER, FOR HAND ACCESS BY OTHERS.
- DESIGN LOAD: H-20 TRAFFIC FROM 1' TO 6' OF COVER PER ASTM C890 & C915 AND ASSHTO LOADING METHODS.
- CONTACT JENSEN PRECAST FOR OTHER INSTALLATION DEPTHS, INLET/OUTLET CONFIGURATIONS AND/OR LOADING CONDITIONS FOR STRUCTURAL DESIGN REVISION TO MEET PROJECT SPECIFIC NEEDS.

CONSTRUCTION NOTES :

- CONTRACTOR TO VERIFY VERTICAL DIMENSIONS OF ALL PRECAST PIECES IN FIELD.
- VERIFY BASE MATERIAL ELEVATIONS BEFORE PLACING PRECAST COMPONENTS OR BACKFILLING.
- APPLY BUTYL MASTIC AND/OR GROUT TO SEAL JOINTS OF MANHOLE STRUCTURE.
- APPLY LOAD TO MASTIC SEAL IN JOINTS OF TANK SECTIONS TO COMPRESS SEALANT IF NECESSARY. UNIT MUST BE WATER TIGHT, HOLDING WATER UP TO FLOWLINE INVERT (MINIMUM).
- ALL INTERNAL COMPONENTS INSTALLED BY MANUFACTURER.

MATERIALS :

- ALL DIMENSIONS ARE IN FEET OR DECIMAL INCHES.
- PRECAST MATERIALS AND MANUFACTURING METHODS SHALL CONFORM TO ASTM C-857 & C-478.
- CONCRETE SHALL HAVE A MINIMUM COMPRESSIVE STRENGTH F'c = 5,000-psi AT 28-DAYS.
- THE PORTLAND CEMENT USED IN THE PRECAST SECTION SHALL MEET THE REQUIREMENTS OF TYPE II/V HIGH SULFATE RESISTANT CEMENT IN ACCORDANCE WITH ASTM CLASS M C-150.

LIFTING WEIGHTS :

- HAVIEST PICK WEIGHT IS XX,XXX-LBS.
- JENSEN CRANE TRUCK CAN SET A MAXIMUM OF 25,000-LBS AT 15-FT OFFSET DISTANCE FROM CENTER OF CRANE TRUNNION.

MATERIALS LIST - PROVIDED WITH UNIT :

QTY	COMPONENT DESCRIPTION	MATERIAL PROVIDER	RESPONSIBLE INSTALLER
1	XX" Ø HDPE/RCP/PVC INLET PIPE STUB	JENSEN	JENSEN
1	XX" Ø HDPE/RCP/PVC OUTLET PIPE STUB	JENSEN	JENSEN
1	XX" Ø HDPE/RCP/PVC TEE, ORIFICE PLATE AND VERTICAL PIPE	JENSEN	JENSEN
1	ORIFICE SCREEN	JENSEN	JENSEN
6	OIL & GREASE ABSORPTION PAD	JENSEN	CONTRACTOR
21	24" Ø CAST IRON FRAME AND COVER, H2O RATED	JENSEN	CONTRACTOR
X	3" GRADE RINGS	JENSEN	CONTRACTOR
X	6" GRADE RINGS	JENSEN	CONTRACTOR
X	12" GRADE RINGS	JENSEN	CONTRACTOR

MODEL: JPHV-28000 HORIZONTAL FLOW CLARIFIER LAMINAR SEDIMENTATION		PROJECT: PROJECT NAME CITY, STATE		JANSEN WATER RESOURCES 521 DUNN CIRCLE, SPARKS, NV 89431-6312 (877) 649-0095 FAX (775) 440-2013	
Sedimentation, Oil & Grease, Floatable Debris		ORG. DWG. DATE 2/21/2020	SCALE: AS SHOWN	SHEET SIZE 11" X 17"	DRAWN BY X.XXXX
				SHEET NUMBER JPHV-28000	