

# 360-S SERIES STANDARD SIMPLEX PUMP STATION

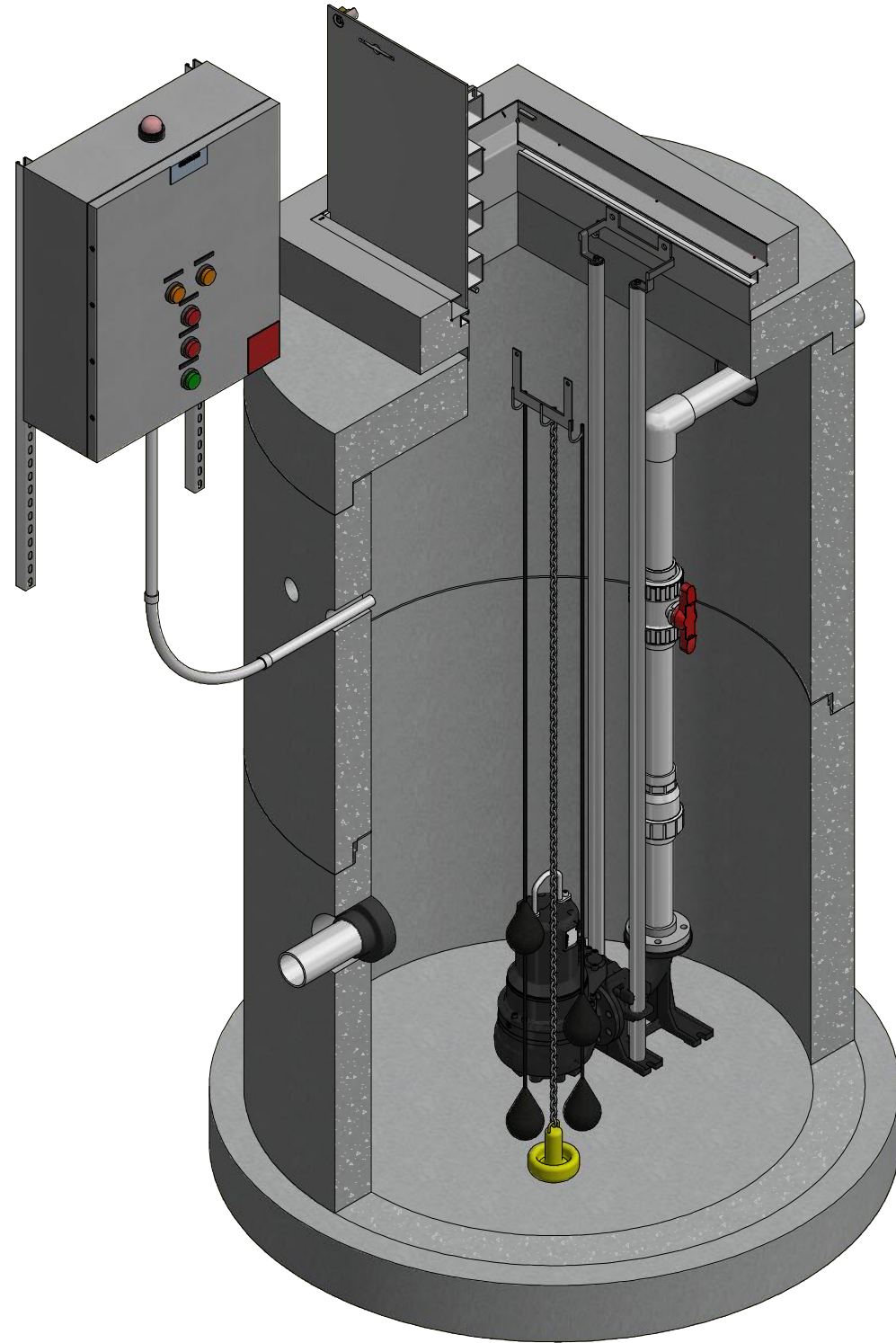

TOP LEFT ISOMETRIC VIEW w/ SECTION  
NOT TO SCALE

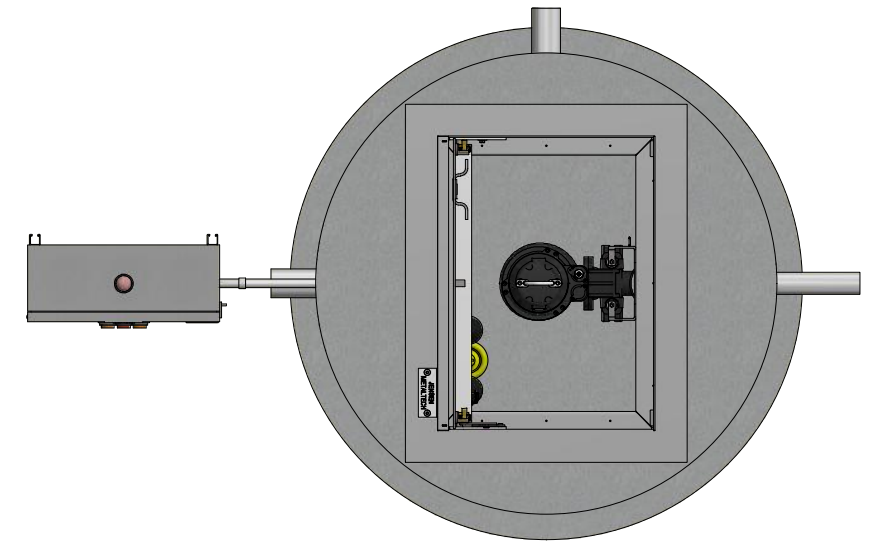

PLAN VIEW  
NOT TO SCALE

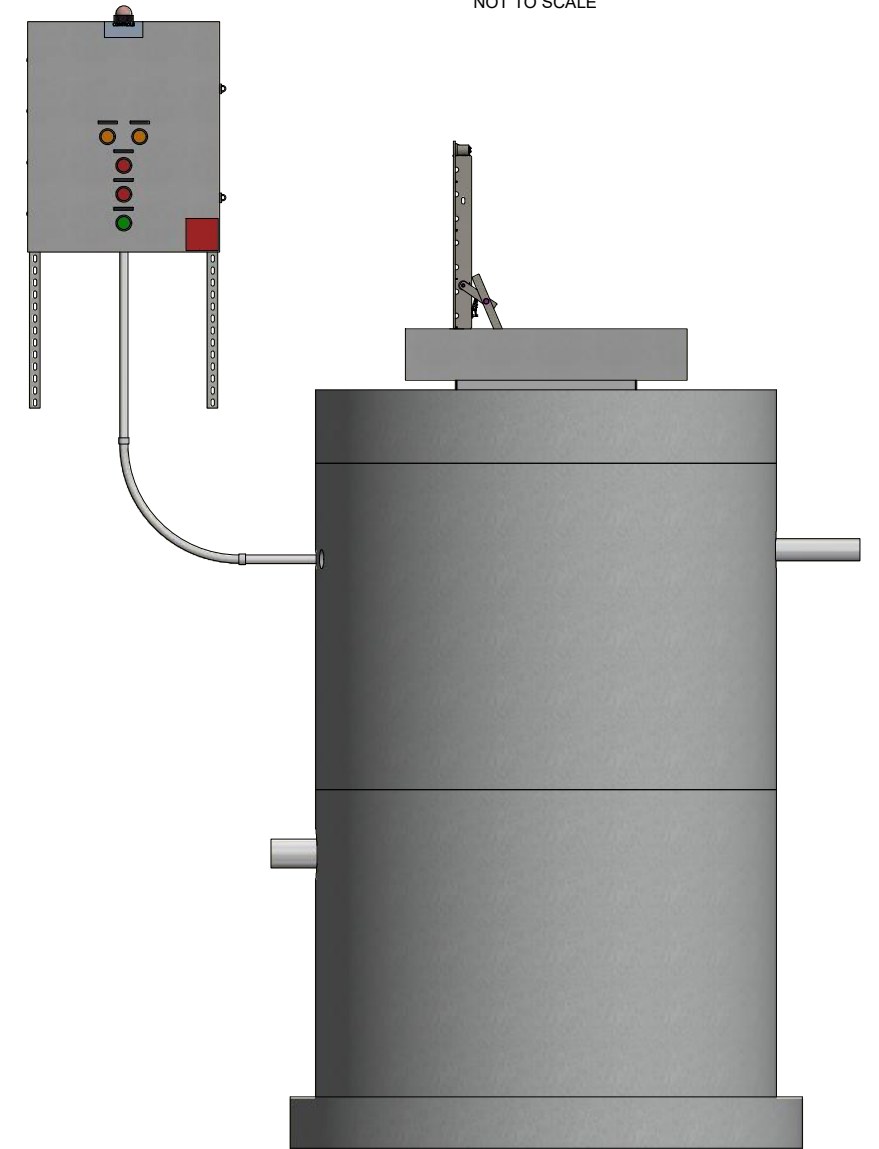

PROFILE VIEW  
NOT TO SCALE

360-S Series Standard.idw

**DISCLAIMERS, INCLUDING BUT NOT LIMITED TO:**

- 1.) All elevations have been provided by others, and have not been verified by Jensen Precast. Contractor to verify all dimensions and elevations in field prior to installation.
- 2.) These layout drawings are intended to show overall system design only. All concrete component thicknesses, dimensions, and joint orientations may vary across Jensen Precast's manufacturing facilities. Contractor to confirm all thicknesses, dimensions, and joint orientations prior to installation.
- 3.) System design criteria has been provided to Jensen Precast. Others are responsible for verification that system meets intended application.
- 4.) Foundation, subgrade, and backfill to be designed by others.

**JENSEN**  PUMP STATIONS  
521 DUNN CIRCLE, SPARKS, NV 89431  
[www.jensenwaterresources.com](http://www.jensenwaterresources.com)  
(855) 468-5600

©2018 Jensen Precast - All rights reserved.  
All materials appearing as Jensen Precast documents and the like are proprietary work product and are protected under U.S. copyright and other laws.  
Unless in conjunction with business conducted with Jensen Precast, any use of Jensen Precast work product without express, written consent is prohibited, and recipient is prohibited from distributing any and all work product to non-approved third parties under penalty of civil action.

DESCRIPTION:		360-S SERIES STANDARD		REV:
TITLE SHEET				SHEET:
PART NUMBER:	360-S Series Standard	DRAWN BY:	T. Handke	1 OF 2
CREATED:		MODIFIED:	4/28/2020	

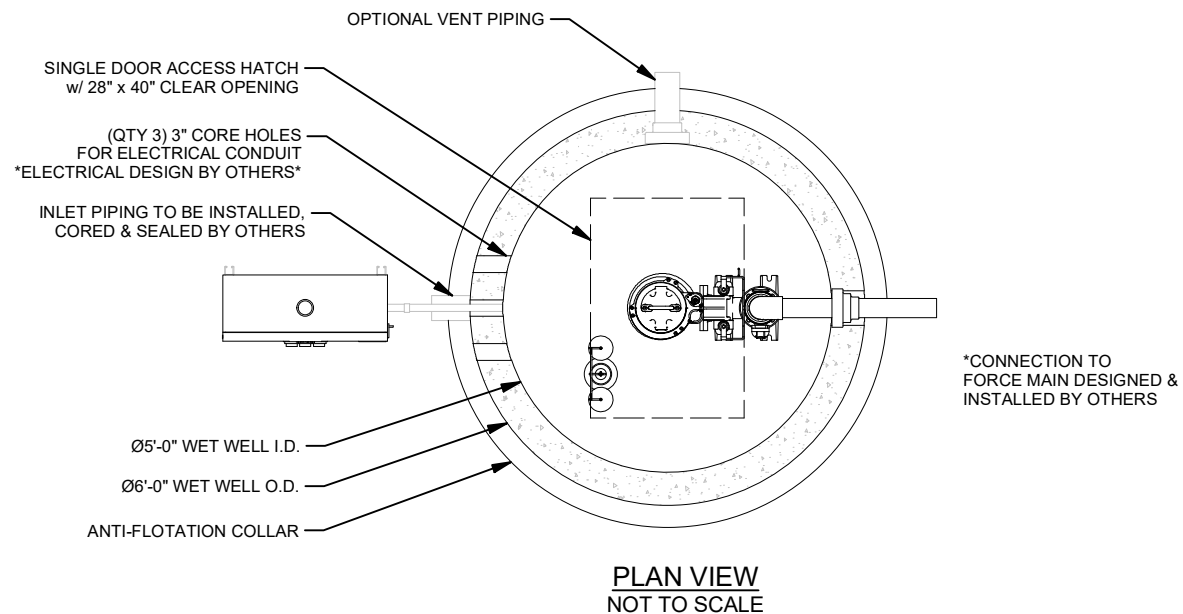

BILL OF MATERIALS		
ITEM	QTY	DESCRIPTION
1	1	SIMPLEX CONTROL PANEL
2	1	60IN DIA. JENSEN PRECAST CONCRETE MANHOLE BASE *HEIGHT VARIES*
3	1	60IN DIA. JENSEN PRECAST CONCRETE MANHOLE BARREL *HEIGHT VARIES*
4	1	60IN DIA. JENSEN PRECAST CONCRETE MANHOLE FLAT TOP
5	1	JENSEN PRECAST CONCRETE HATCH RISER
6	1	SINGLE DOOR HATCH WITH A CLEAR OPENING OF 28IN X 40IN
7	1	UPPER GUIDE RAIL BRACKET 3IN
8	1	FLOAT BRACKET 3 HOOK TYPE 316SS
9	10 LF	LF CHAIN 1/4IN 316SS
10	4	FLOAT SWITCH w/ 100' CABLE
11	1	ANCHOR 15LB PVC COATED
12	1	3IN SUBMERSIBLE PUMP
13	1	AUTOCOUPLING ASSY 3IN FLG
14	1	ADAPTER 3IN FLG X SLIP SCH 80 PVC
15	20 LF	LF PIPE PVC SCH 80 3IN DIA
16	1	BALL CHECK VALVE 3IN SCH 80 PVC SLIP
17	20 LF	LF PIPE 1.5IN SCH40 GUIDE RAIL 304SS
18	1	BALL VALVE 3IN SCH 80 PVC SLIP
19	1	90 DEG ELBOW 3IN SCH 80 PVC SLIP
20	1	FLEXIBLE PIPE CONNECTOR

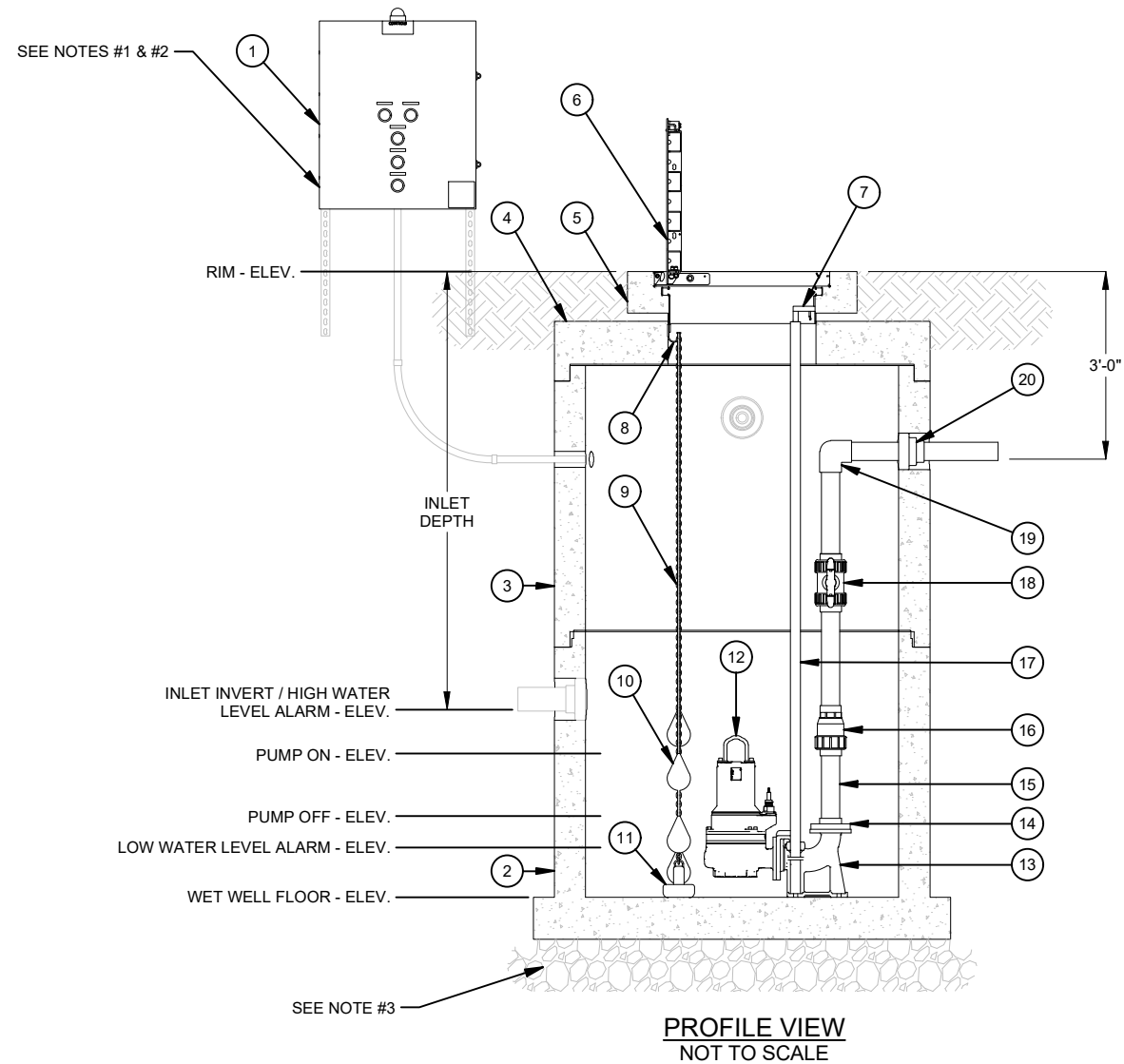

**DESIGN NOTES / DISCLAIMERS:**  
 1. CONTROL PANEL INSTALLATION, MOUNTING DESIGN & HARDWARE BY OTHERS.  
 2. FINAL CONTROL PANEL LOCATION TO BE DETERMINED ACCORDING TO PROJECT REQUIREMENTS. CONSULT ALL SUBMITTED PUMP AND LEVEL CONTROL CABLE LENGTHS WHEN DETERMINING THE CONTROL PANEL LOCATION.  
 3. ALL FOUNDATION, SUBGRADE, AND BACKFILL DESIGNED BY OTHERS.

PROJECT SPECIFIC INFORMATION	
FINISHED GRADE (Ft.)	
RIM ELEV. (Ft.)	
INLET ELEV. (Ft.)	
FORCE MAIN DISCHARGE ELEV. (Ft.)	
AVAILABLE POWER SUPPLY	120V [ ] 240V [ ] 480V [ ]
AVAILABLE POWER PHASE	Single [ ] Three [ ]

SYSTEM CHARACTERISTICS		
APPLICATION	SEWAGE [ ]	STORM WATER [ ]
DESIGN FLOW (gpm)		
TOTAL DYNAMIC HEAD (Ft.)		
STATIC HEAD (Ft.)		
PUMP MOTOR (Std / XP)	Standard [ ]	XP/FM [ ]
PUMP TYPE	Non-Clog [ ]	Grinder [ ] Chopper [ ] Vortex [ ]
PUMP RATED HP & CURRENT		
ACCESS HATCH LOAD LEVEL	Pedestrian [ ]	Incidental H-20 [ ] Parking Lot H-20 [ ] Full Traffic H-20 [ ]

ADDITIONAL OPTIONS		
OPTION	YES	NO
CONTROL PANEL SS ENCLOSURE	[ ]	[ ]
CONTROL PANEL AC UNIT	[ ]	[ ]
CONTROL PANEL REMOTE ALARM MONITORING	[ ]	[ ]
AIR RELEASE/VACUUM VALVE	[ ]	[ ]
INTERIOR LINER	[ ]	[ ]
CONCRETE WATERPROOFING	[ ]	[ ]
VENT PIPE	[ ]	[ ]
ODOR CONTROL VALVE	[ ]	[ ]
LIFTING CRANE	[ ]	[ ]
GENERATOR RECEPTACLE	[ ]	[ ]

**DISCLAIMERS, INCLUDING BUT NOT LIMITED TO:**  
 1.) All elevations have been provided by others, and have not been verified by Jensen Precast. Contractor to verify all dimensions and elevations in field prior to installation.  
 2.) These layout drawings are intended to show overall system design only. All concrete component thicknesses, dimensions, and joint orientations may vary across Jensen Precast's manufacturing facilities. Contractor to confirm all thicknesses, dimensions, and joint orientations prior to installation.  
 3.) System design criteria has been provided to Jensen Precast. Others are responsible for verification that system meets intended application.  
 4.) Foundation, subgrade, and backfill to be designed by others.

**JENSEN** PUMP STATIONS  
 521 DUNN CIRCLE, SPARKS, NV 89431  
 www.jensenwaterresources.com  
 (855) 468-5600

©2018 Jensen Precast - All rights reserved.  
 All materials appearing as Jensen Precast documents and the like are proprietary work product and are protected under U.S. copyright and other laws.  
 Unless in conjunction with business conducted with Jensen Precast, any use of Jensen Precast work product without express, written consent is prohibited, and recipient is prohibited from distributing any and all work product to non-approved third parties under penalty of civil action.

DESCRIPTION: **360-S SERIES STANDARD**  
 MECHANICAL DETAIL  
 PART NUMBER: 360-S Series Standard  
 DRAWN BY: T. Handke  
 CREATED: [ ]  
 MODIFIED: 4/28/2020  
 REV: [ ]  
 SHEET: 2 OF 2

360-S Series Standard.dwg