

# JENSEN DEFLECTIVE SEPARATOR, MODEL JDS144-94102-OFFLINE

## HYDRAULICS AND TREATMENT :

MAXIMUM TREATMENT FLOW RATE (MTFR)	≤ 8.32 - CFS
WATER QUALITY DESIGN STORM (WQDS)	XX.XX - CFS
RETURN FREQUENCY/PERIOD OF PEAK DESIGN CONVEYANCE FLOW	XXXX - YRS
DIVERSION WEIR CREST ELEVATION	XXXX.XX' ±

STORMWATER TREATMENT UNIT EMPLOYING THE CONTINUOUS DEFLECTIVE SEPARATION TREATMENT PROCESS TO PRODUCE A NON-BLOCKING SCREENING SYSTEM WITH SWIRL CONCENTRATION. THIS HYDRODYNAMIC SEPARATION TREATMENT IS EQUIPPED WITH AN INTERNAL BYPASS THAT PROVIDES COMPLETE BYPASS OF STORM DRAIN PIPELINE CONVEYANCE FLOW WITHOUT SCOUR OF CAPTURED GROSS SOLIDS .

## TREATMENT :

- THIS HYDRODYNAMIC SEPARATOR (HDS), IS A PROPRIETARY MANUFACTURED TREATMENT DEVICE (MTD), BEST MANAGEMENT PRACTICE (BMP), THAT ACHIEVES 50% TSS REMOVAL EFFICIENCY VERIFIED BY THE NEW JERSEY CORPORATION FOR ADVANCED TECHNOLOGY (NICAT), AND CERTIFIED BY THE NEW JERSEY DEPARTMENT OF ENVIRONMENTAL PROTECTION (NJDEP).
- THIS 50% TSS REMOVAL EFFICIENCY IS ACHIEVED ON A PARTICLE SIZE DISTRIBUTION (PSD), HAVING A  $d_{50} \leq 62$ -MICRONS.
- PER THE NJDEP CERTIFICATION, THE MAXIMUM TREATMENT FLOW RATE (MTFR), GENERATES A HYDRAULIC SURFACE LOADING RATE OF 33-GPM/FT<sup>2</sup>.
- CERTIFIED FOR 100% CAPTURE FOR TRASH & DEBRIS BY CALIFORNIA STATE WATER RESOURCES CONTROL BOARD.
- JENSEN DEFLECTIVE SEPARATOR IS A NON-BLOCKING SCREENING UNIT.
- JENSEN DEFLECTIVE SEPARATOR DESIGNED TO PROCESS ENTIRE SQDF.
- CAPTURE OF OTHER WATER QUALITY CONSTITUENTS INCLUDE:
  - TOTAL SUSPENDED SOLIDS (TSS)
  - HEAVY METALS
  - OIL & GREASE
  - NUTRIENTS
  - FECAL COLIFORM

## DIVERSION STRUCTURE DESIGN NOTES :

- FINAL DIVERSION STRUCTURE/VAULT DIMENSIONS TO BE DETERMINED (TBD) FROM ENGINEERING AND HYDRAULIC & ENERGY GRADELINE ANALYSES.

## DESIGN PARAMETERS :

- STANDARD CONFIGURATION IS SHOWN. ALTERNATE CONFIGURATIONS ARE READILY AVAILABLE. CONTACT JENSEN STORMWATER SYSTEMS FOR CUSTOM DESIGNS, [www.jensenengineeredsystems.com](http://www.jensenengineeredsystems.com).
- FOR COMPLETE DESIGN AND PRODUCT INFORMATION, CONTACT JENSEN STORMWATER SYSTEMS.
- FOUNDATION, SUBGRADE, AND BACKFILL TO BE DESIGNED BY OTHERS.
- GROUNDWATER ELEVATION IS ASSUMED TO BE BELOW THE BOTTOM OF PRECAST STRUCTURE. CONTACT JENSEN STORMWATER SYSTEMS FOR HIGH GROUNDWATER CONDITIONS.
- JENSEN STORMWATER SYSTEMS TO PROVIDE ALL MATERIALS AS SHOWN, UNLESS OTHERWISE NOTED.
- OUTLET INVERT ELEVATION TYPICALLY SET EQUAL TO INLET ELEVATION OR SET 1" LOWER THAN INLET.

## INSTALLATION NOTES :

- CONTRACTOR TO VERIFY ALL DIMENSIONS AND ELEVATIONS IN FIELD PRIOR TO INSTALLATION.
- PRECAST CONCRETE JOINTS TO BE SEALED USING BUTYL RUBBER COMPOUND SUPPLIED BY JENSEN PRECAST.
- CONTRACTOR TO GROUT ALL PIPE PENETRATIONS IN PRECAST CONCRETE OPENINGS IN FIELD AS NECESSARY.
- CONTRACTOR TO ADJUST ELEVATION OF FRAME AND COVER IN FIELD AS NECESSARY.

## MATERIALS :

- ALL DIMENSIONS ARE IN FOOT-INCH.
- PRECAST MATERIALS AND MANUFACTURING METHODS SHALL CONFORM TO ASTM C-478, C-857 AND LACSD S-A-206, WHEN IN LA COUNTY.
- CONCRETE SHALL HAVE A MINIMUM COMPRESSIVE STRENGTH  $F'c = 4,000$ -psi AT 28-DAYS.
- THE PORTLAND CEMENT USED IN THE PRECAST SECTION SHALL MEET THE REQUIREMENTS OF TYPE II/V HIGH SULFATE RESISTANT CEMENT IN ACCORDANCE WITH ASTM CLASS M C-150.
- MANHOLE COMPONENTS CONFORM TO CURRENT SPECIFICATIONS, ASTM, C-478 AND AASHTO M199.
- FLAT TOPS AND BASE SLABS ARE DESIGNED FOR ASSHTO HS-20 WHEEL LOADING.
- ALL PRECAST CONCRETE COMPONENTS TO BE MANUFACTURED IN A NPCA CERTIFIED PLANT.

QTY.	COMPONENT DESCRIPTION	RESPONSIBLE PROVIDER	RESPONSIBLE INSTALLER
1	SEPARATION SCREEN AND INLET CYLINDER	JENSEN	CONTRACTOR
1	30" Ø CAST IRON FRAME AND COVER, H20 RATED	JENSEN	CONTRACTOR
X	3" TALL 36" Ø GRADE RINGS	JENSEN	CONTRACTOR
X	6" TALL 36" Ø GRADE RING	JENSEN	CONTRACTOR
1	XX" Ø HDPE/PVC/RCP INLET PIPE	CONTRACTOR	CONTRACTOR
1	XX" Ø HDPE/PVC/RCP OUTLET PIPE	CONTRACTOR	CONTRACTOR

## (\*) REGIONAL MANUFACTURING DIFFERENCE :

THESE ARE TEMPLATE SITE DESIGN DRAWINGS. JOINTS ORIENTATIONS, AND FINAL SEPARATION AND BASE SLAB THICKNESS VARY ACROSS JENSEN'S REGIONAL MANUFACTURING FACILITIES. CONFIRM FINAL JOINT ORIENTATION AND THICKNESS PER CONSTRUCTION SUBMITTAL DRAWINGS. ADJUST FINAL DIMENSIONS TO EXTERIOR INVERT AND SUBGRADE ELEVATION PER REGION DIFFERENCES.

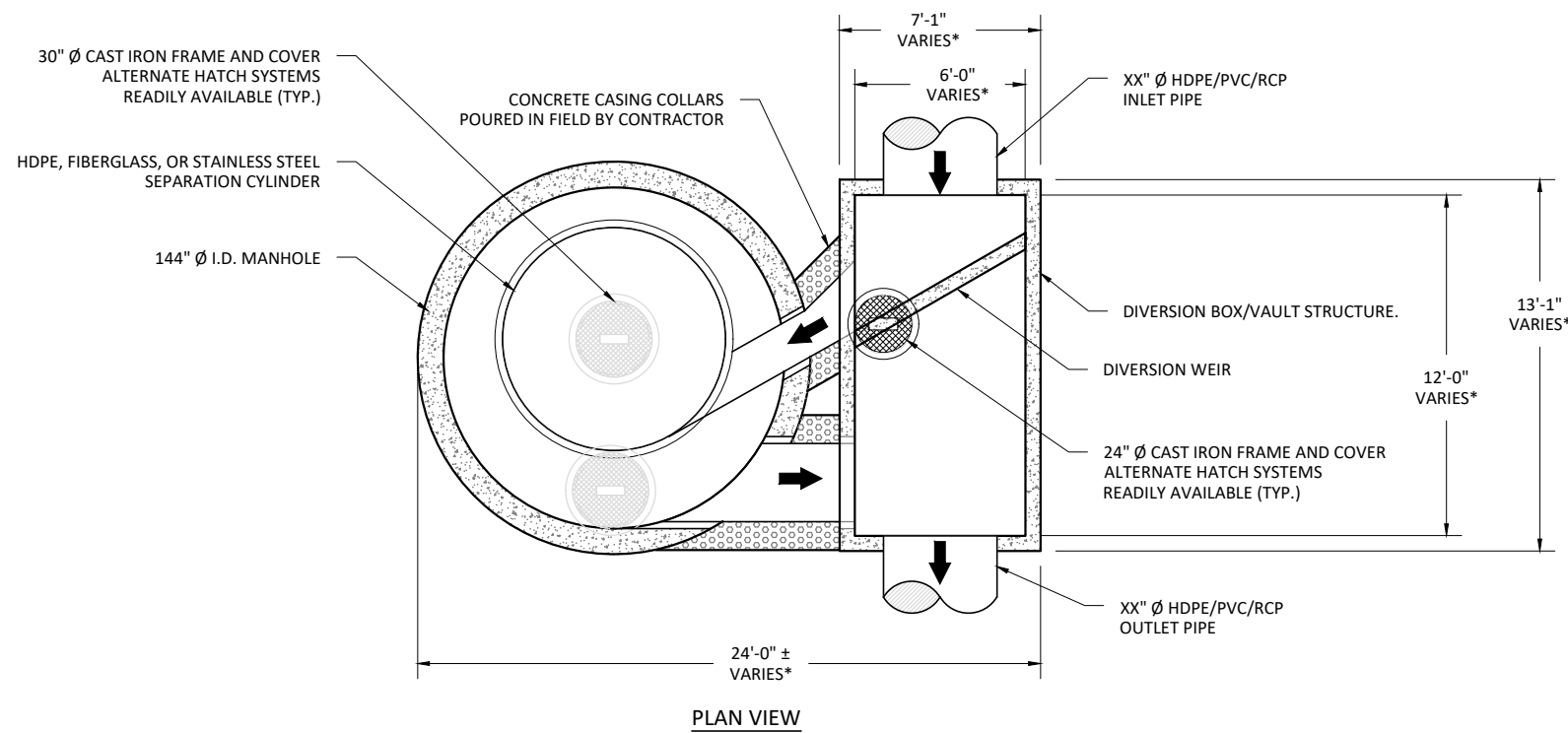

PLAN VIEW

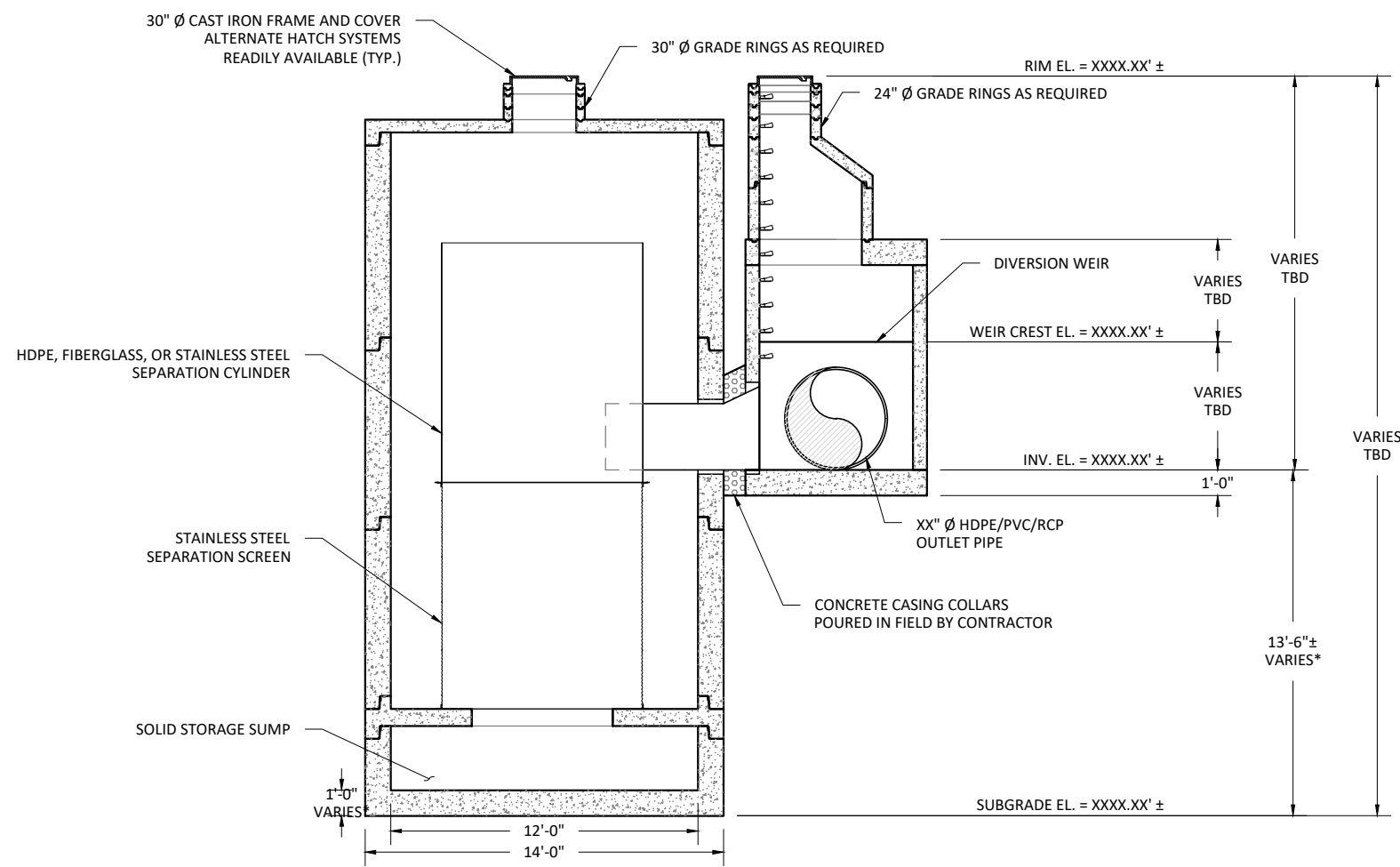

ELEVATION VIEW

MODEL: <b>JDS144-94102 OFFLINE JENSEN DEFLECTIVE SEPARATOR</b>	PROJECT: PROJECT NAME CITY, STATE	<p>521 DUNN CIRCLE, SPARKS, NV 89431-6312 (877) 649-0095 FAX (775) 440-2013 <a href="http://www.jensenengineeredsystems.com">www.jensenengineeredsystems.com</a></p>											
HYDRODYNAMIC SEPARATOR (HDS), SWIRL CONCENTRATING, FULL CAPTURE, NON-BLOCKING SCREENING UNIT	<table border="1"> <tr> <td>ORG. DWG. DATE</td> <td>REV. DWG. DATE</td> <td>SCALE:</td> <td>SHEET SIZE</td> <td>DRAWN BY</td> <td>SHEET NUMBER</td> </tr> <tr> <td>XX/XX/XXXX</td> <td>XX/XX/XXXX</td> <td>1:80</td> <td>11" X 17"</td> <td>X.XXXX</td> <td>1</td> </tr> </table>		ORG. DWG. DATE	REV. DWG. DATE	SCALE:	SHEET SIZE	DRAWN BY	SHEET NUMBER	XX/XX/XXXX	XX/XX/XXXX	1:80	11" X 17"	X.XXXX
ORG. DWG. DATE	REV. DWG. DATE	SCALE:	SHEET SIZE	DRAWN BY	SHEET NUMBER								
XX/XX/XXXX	XX/XX/XXXX	1:80	11" X 17"	X.XXXX	1								