

HYDRODYNAMIC SEPARATORS

Full Capture, Screening, Swirl-Concentrating Stormwater Treatment Systems

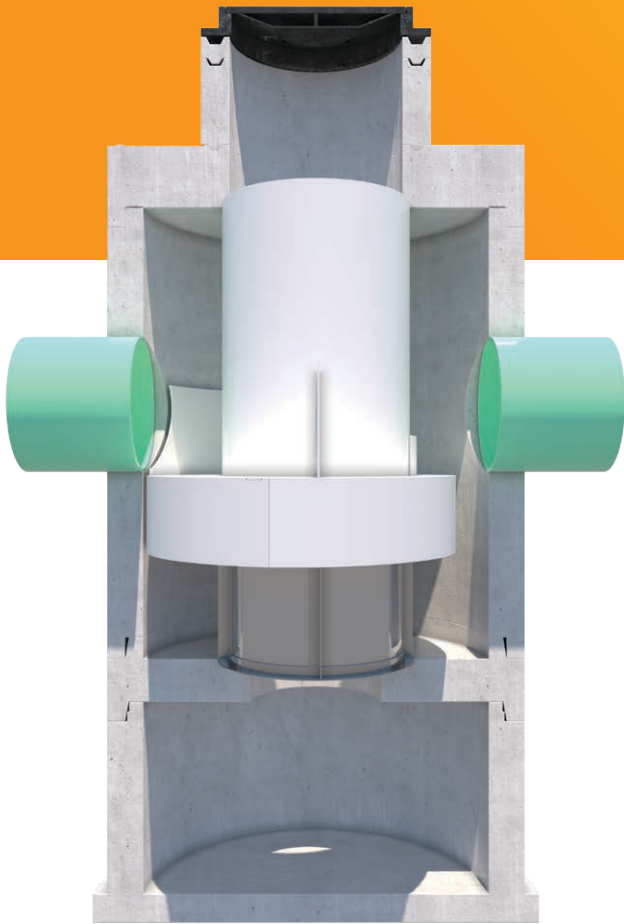

JENSEN DEFLECTIVE SEPARATOR

With no moving parts, the JDS is uniquely able to screen trash and debris including floatables, and both neutrally and negatively buoyant materials, from stormwater, all without blocking the screen. The JDS also captures total suspended solids (TSS), oil, grease, and other total petroleum hydrocarbon (TPH) pollutants from stormwater runoff. Captured pollutants are retained without scouring, even under high-flow bypass conditions.



DESIGN

- Leverage proven continuous deflective treatment process for full capture of 100% of trash and debris $\geq 5\text{mm}$.
- Treat large flow ranges from .7 to 83 CFS with inline and offline units.
- Save with the most cost effective treatment method per cfs of stormwater as compared to other structural BMPs.



BID

- Meet full capture requirements with state certified treatment systems.
- Bid an equivalent system directly from the manufacturer to save time and money.
- Receive a complete package quote that includes all your precast sewer and storm drainage products.



BUILD

- Install using standard methods with a JDS unit configured inside a precast manhole set below grade.
- Maintain your system easily and safely by opening the unit through multiple large accessways and removing trash and debris with a standard vacuum truck.



JDS Removes 100% of Trash and Debris

STANDARD JDS INLINE UNIT

- 1** Stormwater enters the JDS unit from one or more inlet pipes, a grated drop or curb inlet.
- 2** Incoming water collects in the fore bay of the inlet trough.
- 3** Waters enter the separation and screening cylinder through the volute entrance in the diversion weir wall.
- 4** Water entering the separation cylinder forms a spinning vortex, capturing all floatables and swirl concentrating suspended solids to the center of the separation chamber.

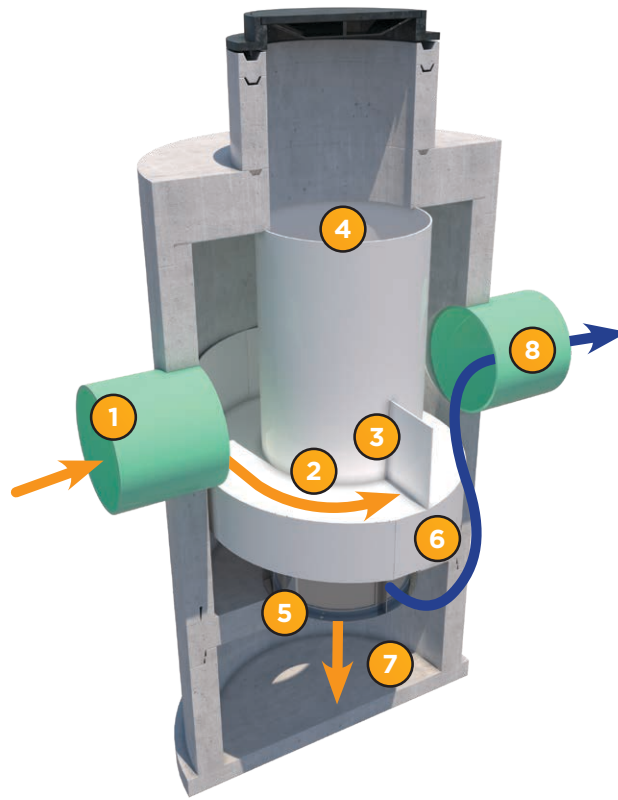

- 5** The vortex flow pattern produces a washing force across the screen face, preventing it from becoming blocked, while allowing stormwater to pass through the screen and flow beneath the oil baffle.
- 6** Oils, greases and other Total Petroleum Hydrocarbons (TPHs) are trapped within the integral oil baffle attached beneath the inlet bay.
- 7** Settled and swirl concentrated suspended solids are captured in the sump which is typically cleaned out by a vacuor truck.
- 8** Flows larger than the JDS unit's design treatment flow bypass over the diversion weir. Bypass flows do not scour out previously captured pollutants.

The JDS offers a unique non-blocking and non-mechanical screening process with no moving parts and no power requirements.

CERTIFICATIONS



The California State Water Resources Control Board has certified the JDS system as a Full Capture System Device for Trash Treatment Control.



New Jersey Corporation for Advanced Technology verified the JDS for 50% or greater TSS Removal.



New Jersey Department of Environmental Protection Certified