

2'-0" x 3'-0" EDISON PAD MOUNT SWITCH ENCLOSURE x 36" DEEP

NOTES:

- DUCTED PULL BOX DESIGNED FOR H-20-44 TRAFFIC LOADING USING 5300 PSI (37.132MPa) COMPRESSIVE STRENGTH A-706 REINFORCING STEEL PER CALCS #30958.
- PMH PAD DESIGN PER EDISON SPECIFICATION
- ENCLOSURE TO BE PLACED ON A 6" BASE OF CRUSHER RUN FOR EVEN LOAD DISTRIBUTION AND EASE OF INSTALLATION.
- CONCRETE MIX USED IN POURING THIS PRODUCT SHALL US FLY ASH AS AN ADMIXTURE:

FOLLOWING TO BE SHIPPED WITH PMH PAD:

- (a) 1/2" x 2 1/2" P-36-T TEMPORARY COVER (1) REQ'D.
- (b) 1/2" x 2 1/2" P-36-T PERM-HEAD STAINLESS
- (c) 1/2" x 2 1/2" HEX HEAD PLATED BOLT (4 REQ'D).

ORDERING INFORMATION:

K2436-PUV36-11 FOR ASSEMBLY AS SHOWN.
 PER EDISON SPEC. UGS 592.1
 TOTAL WEIGHT OF ASSEMBLY AS SHOWN IS 3,095 Lbs.

GENERAL NOTES:

1. Minimum soil bearing capacity is hereby assumed to be 2000 Psf. A geotechnical report shall be provided to Jensen Precast by the end user. Jensen Precast shall not be held responsible for the soil bearing capacity. Handholes, Meter Boxes etc. will be as per Jensen installation procedures.
2. Structural modification to the Jensen line of products is not allowed without prior written approval from Jensen Precast Engineering Department. Do not scale the drawings, verify all dimensions including rough openings, if any discrepancies are found, notify Jensen Engineer immediately.
3. The Jensen Engineer will interpret the intent of the drawings in case of possible conflict or discrepancy.
4. Permissible Tolerances:
 - Dimensional Tolerances - The length, width, height, or dia. measurements of the structure when measured on the inside surfaces shall not deviate from design dimensions by more than the following:
 - 0 to 5 Feet 1/4"
 - 5 to 10 Feet 3/8"
 - 10 to 20 Feet as agreed upon between the supplier and purchaser.
 - Squareness Tolerance: The inside of the precast concrete structure shall be square as determined by diagonal measurements. The difference between such measurements shall not exceed the following:
 - Measured Length: Allowable Difference 1/8" to 1/4"
 - 10 to 20 Feet 3/4"
 - 20 Feet and over as agreed upon between the supplier and purchaser.

1. PB2436D-B30-05, 30" BOTTOM SECTION, WT. 1,995 Lbs.
2. P2436-P-11, 8" THICK PMH PAD, WT. 1,100 Lbs.
3. SC2436-PUV11 TEMPORARY COVER (1) REQ'D. (NOT SHOWN).
4. 6" x 7" DIA. SLUMP X 4" DEEP. LOCATE AS FOLLOWS: (1) DUCTED K-CORE (1) 1/2" DEEP. DRAFT AS FOLLOWS: T=6", S1=52-5", B=0. LOCATE AS FOLLOWS: 8" x 16" K.O. X 3" DEEP. DRAFT AS FOLLOWS: BOTTOM SECTION (2) CORE MTD.
5. 1" DIA. BLIND GROUND HOLE. LOCATE AS FOLLOWS: BOTTOM SECTION (2) CORE MTD.
6. 1/2" DIA. X 9" VERTICAL PULL IRON. BOTTOM SECTION (2) CORE MTD.
7. 1/8" DIA. X 9" VERTICAL PULL IRON. BOTTOM SECTION (2) CORE MTD.
8. @ 1/2" P-36-T INSERT. LOCATE AS FOLLOWS: PMH PAD (8) TABLE MTD.
9. @ 1/2" P-36-T INSERT. LOCATE AS FOLLOWS: PMH PAD (8) TABLE MTD.
10. @ 1/2" P-36-T INSERT. LOCATE AS FOLLOWS: PMH PAD (8) TABLE MTD.

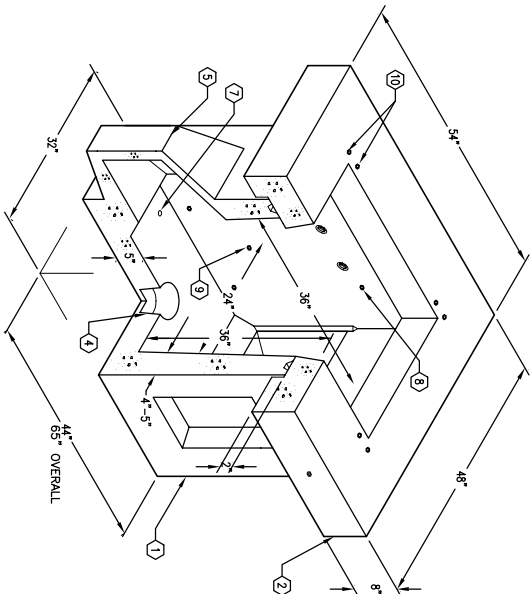

MAIN ELEVATION SIZE
 1/8" = 1'-0" = 1.0000 FT
 1/4" = 1'-0" = 1.0000 FT

K2436-PUV36-11
 PER EDISON SPEC. UGS 592

03-01-02

JENSEN PRECAST

| DATE | DESCRIPTION | BY |
|------|-------------|----|
| | | |

K2436-PUV36-11
 PER EDISON SPEC. UGS 592

03-01-02

SECTION A-A

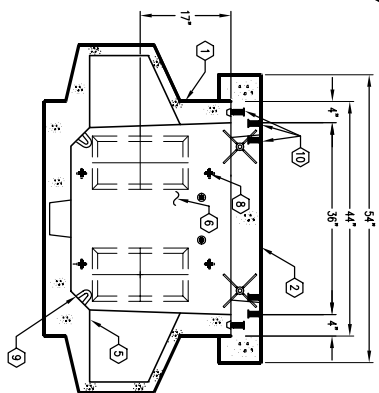

SECTION B-B

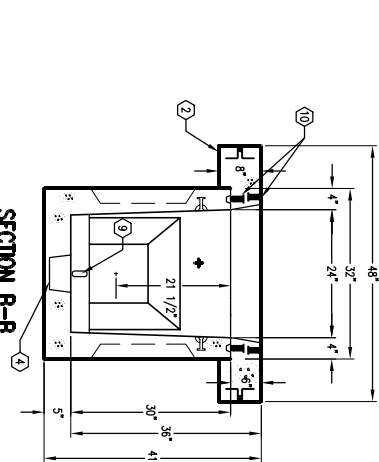

PLAN VIEW
 NOTE: PAD NOT SHOWN IN THIS VIEW FOR CLARITY.

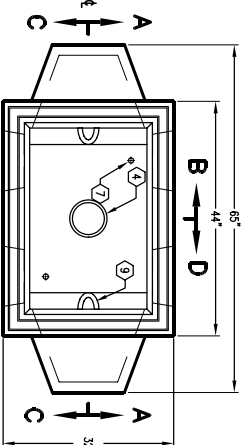

PLAN VIEW OF PAD

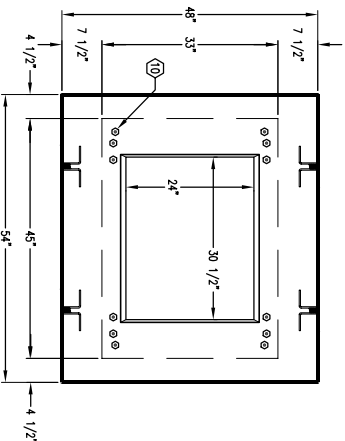

SECTION C-C

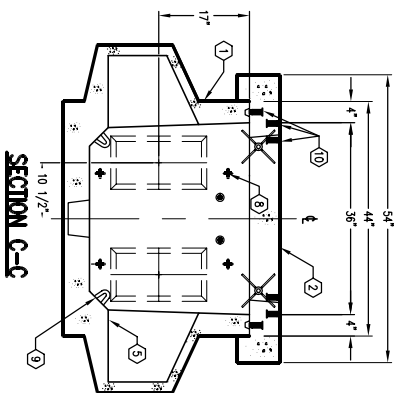

SECTION D-D

