

4'-0" X 6'-0" X 6" RIVERSIDE PADMOUNTED SWITCH PAD

NOTES:

TRANSFORMER PAD DESIGNED IN ACCORDANCE WITH PARKWAY LOADING USING 4,000 PSI COMPRESSIVE STRENGTH CONCRETE AND 60,000 PSI YIELD STRENGTH ASTM A-706 STEEL REINFORCEMENT PER CALCS.

TRANSFORMER PAD TO BE PLACED ON A MIN. 6" BASE OF CRUSHER RUN FOR EASE OF INSTALLATION AND EVEN LOAD DISTRIBUTION.

1. PD4872-T6-21, 6" PADMOUNTED SWITCH PAD (R-PD4872-T6-21). WT. 1,539#
2. 17 5/8" X 30 5/8" OPENING. 1/2" DRAFT ALL SIDES. (2) TABLE MTD. LOCATE AS SHOWN

ORDERING INFORMATION:

PD4872-T6-21 FOR PAD AS SHOWN. PER CITY OF RIVERSIDE UGS-651 TOTAL WT. 1,539#.

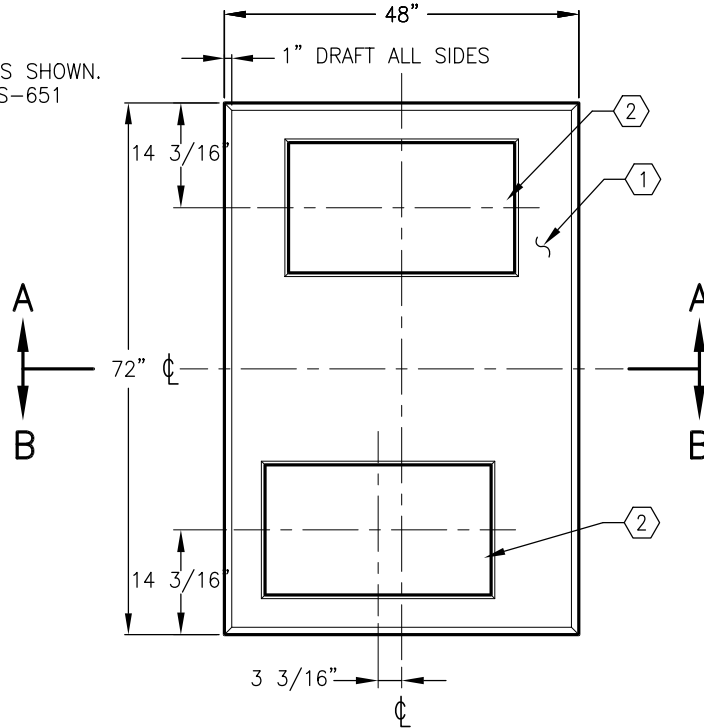

PLAN VIEW

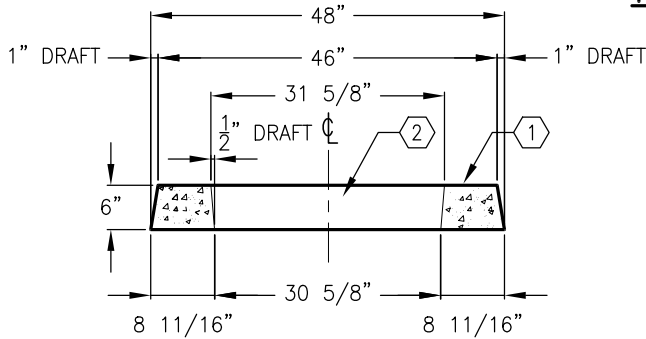

SECTION A-A

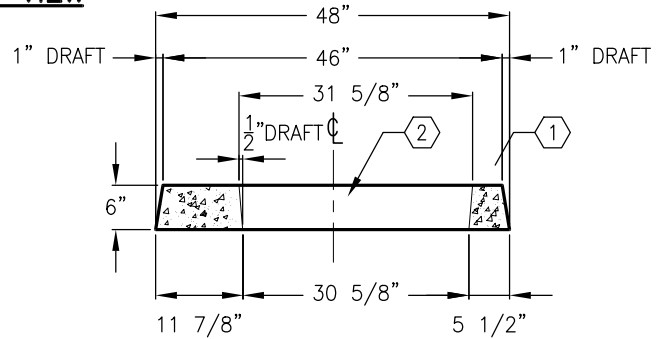

SECTION B-B

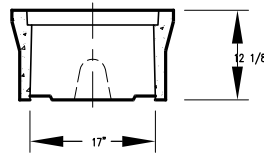
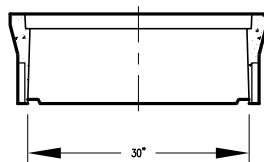

PB66 BODY TWO REQ'D



AUTOCAD REL. 14

| # | DATE | DESCRIPTION | BY |
|---|------|-------------|----|
| | | | |
| | | | |

PD4872-T6-21

CITY OF RIVERSIDE UGS-651

03-01-02