

JP2000-JZ5000 GALLON COMMERCIAL SEPTIC TANKS

TRAFFIC RATED ACCEPTED BY UPC®

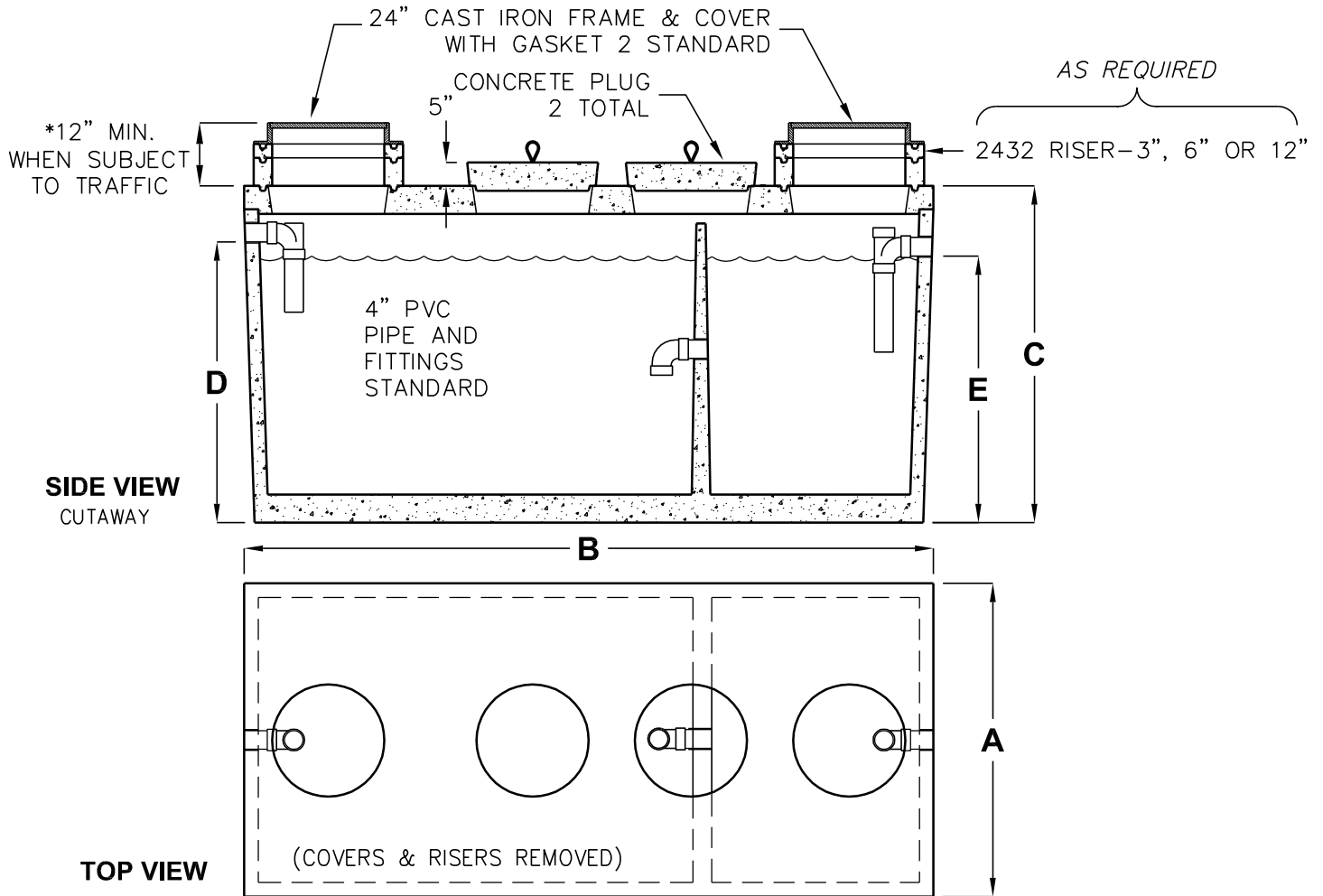

MODEL NUMBER	LIQUID CAPACITY GALLONS	WIDTH 'A'	OVERALL LENGTH 'B'	TANK HEIGHT 'C'	INLET 'D'	OUTLET 'E'	MINIMUM EXCAVATION WIDTH	MINIMUM EXCAVATION LENGTH	* DEPTH OF BURY	MAX. LIFT WEIGHT
JP2000	2000	4'-11"	15'-11"	6'-0"	5'-0"	4'-9"	5'-11"	16'-11"	6' MAX.	19,100
JZ2500	2500	5'-9"	16'-10"	6'-0"	5'-0"	4'-9"	6'-9"	17'-10"	5' MAX.	22,700
JZ3000	3000	5'-9"	16'-10"	6'-9"	5'-9"	5'-6"	6'-9"	17'-10"	5' MAX.	24,000
JZ4000	4000	7'-8"	16'-7"	6'-9"	5'-6"	5'-3"	8'-8"	17'-7"	5' MAX.	22,100
JZ5000	5000	7'-8"	16'-7"	7'-11"	6'-9"	6'-6"	8'-8"	17'-7"	4' MAX.	24,100

- TANK DESIGNED FOR H-20 TRAFFIC WHEEL LOAD WITH DRY SOIL CONDITIONS – (WATER TABLE BELOW TANK.)
- EXTERIOR AND INTERIOR CONCRETE SURFACES TO BE COATED WITH AN APPROVED BITUMINOUS MATERIAL.
- SUITABLE NATIVE OR SUB-BASE SHALL BE PREPARED TO HANDLE ANTICIPATED LOADS. THE EXCAVATION SHALL BE BEDDED WITH SUITABLE GRANULAR MATERIAL AND SHALL BE COMPACTED TO 90% MAXIMUM DRY DENSITY, OR TO REQUIREMENTS OF THE PROJECT GEOTECHNICAL ENGINEER.

THE DESIGN AND DETAIL OF THIS DRAWING ARE THE PROPERTY OF JENSEN PRECAST AND NOT TO BE USED EXCEPT IN CONNECTION WITH ITS OWN WORK. DESIGN AND INVENTION RIGHTS ARE RESERVED.