

7'-0" x 10'-6" "SWITCH" PAD W/5'-0" x 8'-6" ENCLOSURE x 6'-6" DEEP

NOTES:

- CONCRETE IS DESIGNED FOR HS 20-44 TRAFFIC LOADING
- USING 5,500 PSI [37.92MPa] COMPRESSIVE STRENGTH CONCRETE
- AND 60,000 PSI [413.2MPa] REINFORCING STEEL PER CALCS. #30603.
- COVER DESIGNED FOR PARKWAY LOADING.
- PULL BOX TO BE PLACED ON A MINIMUM 6" BASE OF CRUSHER RUN FOR EASE OF INSTALLATION AND EVEN LOAD DISTRIBUTION.

ORDERING INFORMATION:

K586-SB78-25 FOR ASSEMBLY AS SHOWN.

GENERAL NOTES:

1. Minimum soil bearing capacity is hereby assumed to be 2000 PSF unless otherwise documented by a geotechnical report that shall be provided to Jensen Precast by the end user. Jensen Precast shall not be held responsible for the soil bearing capacity. Installation of Manholes, Vaults, Handholes, Meter Boxes etc. will be as per Jensen installation procedures.
2. Structural modification to the Jensen line of products is not permitted without prior written approval from Jensen Engineering Department. Do not scale the drawings, verify all dimensions including rough openings, if any discrepancies are found, notify the Jensen Engineer immediately.
3. The Jensen Engineer will interpret the intent of the drawings in case of possible conflict or discrepancy.
4. Permissible Variations: Dimensional Tolerances - The length, width, height, or dia. measurements of the structure when measured on the inside surfaces shall not deviate from design dimensions by more than the following:
Dimensions: Tolerance:
0 to 5 Feet 1/4"
5 to 10 Feet 3/8"
10 to 20 Feet as agreed upon between the supplier and purchaser.
5. Squariness Tolerance: The inside of the precast concrete component shall be square as determined by diagonal measurements. The difference between such measurements shall not exceed the following:
Measured Length: Allowable Difference
0 to 10 Feet 1/2"
10 to 20 Feet 3/4"
20 Feet and over as agreed upon between the supplier and purchaser.

1. PB586-B42-25 42" BOTTOM SECTION (CG-586-B42-25) WT. 12.68 Lbs.
2. PB586-R24-25 24" RISER SECTION (CG-586-R24-25) WT. 4.350 Lbs.
- 2A. PB586-R13-FT, 13 1/2" TOP RING SECTION FLAT/GROOVE (CG-586-R13 (XXX)) WT. 2.475 Lbs.
3. PD84126-T8-25 8" TRANSFORMER PAD (CG-PD84126-T8-25) WITH 61 1/2" x 50" GALV. STEEL FRAME (F386-PB-ID), AND 24 1/8" x 36" GALV. STEEL FRAME (F2436-PB-ANG). WT. 5,009 Lbs.
4. 26 3/16" x 64 5/8" RPM PARKWAY COVER (12-20-52), (2) REQ'D. 1"ID" x W/(2) EA. DROP HANDLES AND W/2" x 2" x 1/4" REMOVABLE "T" BEAM x 64 1/4" LONG (SCB586-RPM) (1) REQ'D.
5. 27 1/2" x 39 1/2" RPM PARKWAY COVER (12-20-14). 1"ID".
6. 12" x 13" DIA. SUMP KNOCKOUT. (08-2102) LOCATE AS FOLLOWS: BOTTOM SECTION (1) CORE MTD.
7. 6" DIA. CONTERM (6625G). LOCATE AS FOLLOWS: BOTTOM SECTION (24) SHELL MTD.
- 7A. 5" DIA. CONTERM LOCATE AS FOLLOWS: RISER SECTION (16) SHELL MTD.
9. 1" DIA. GROUND HOLE. LOCATE AS FOLLOWS: BOTTOM SECTION (2) CORE MTD.
10. 7/8" DIA. x 3 3/8" GALV. PULL IRON (08-2192). LOCATE AS FOLLOWS: BOTTOM SECTION (6) CORE MTD.
16. 1/2" INSERT (P-35-T). LOCATE AS FOLLOWS: 61 1/2" x 50" GALV. FRAME (8) REQ'D.; 27 1/2" x 39 1/2" GALV. FRAME (4) REQ'D.

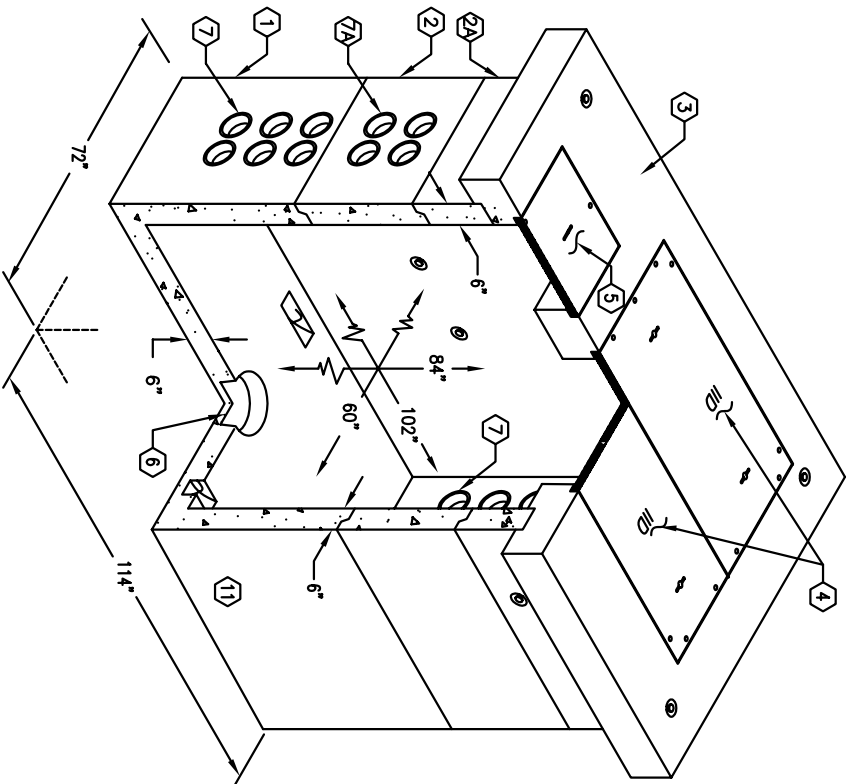

MINIMUM EXCAVATION SIZE:
7'-0" x 10'-6" x DEPTH REQ'D.

K586-SB78-25

PER I.L.D. 856-4 Rev.01 07-26-03

7/12/06



ANPCOD REL. 14

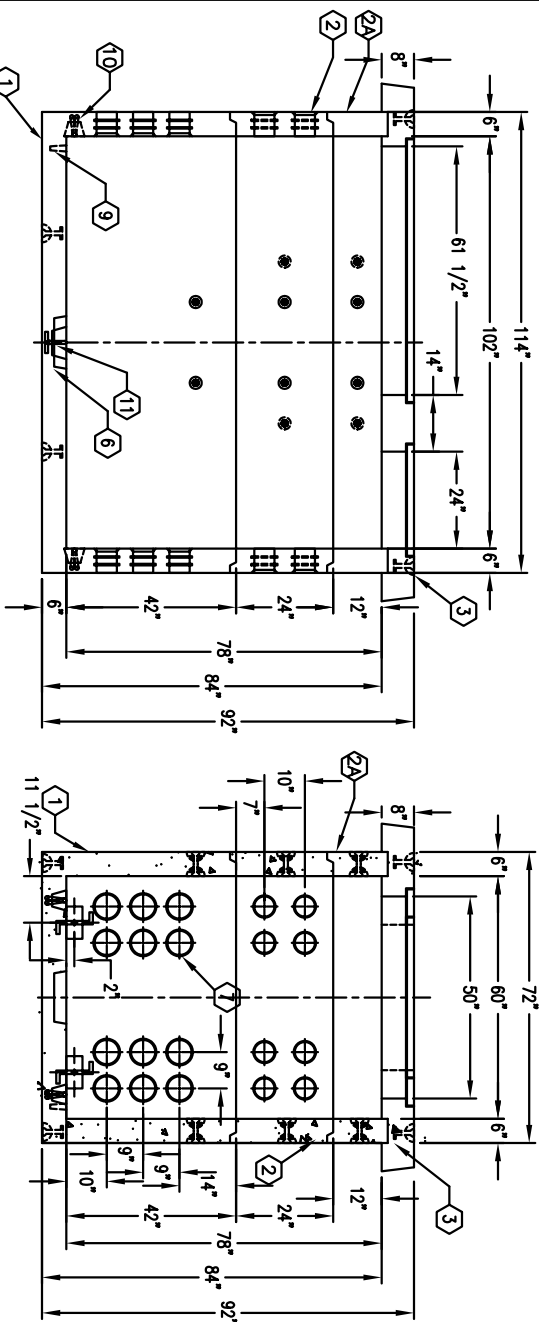
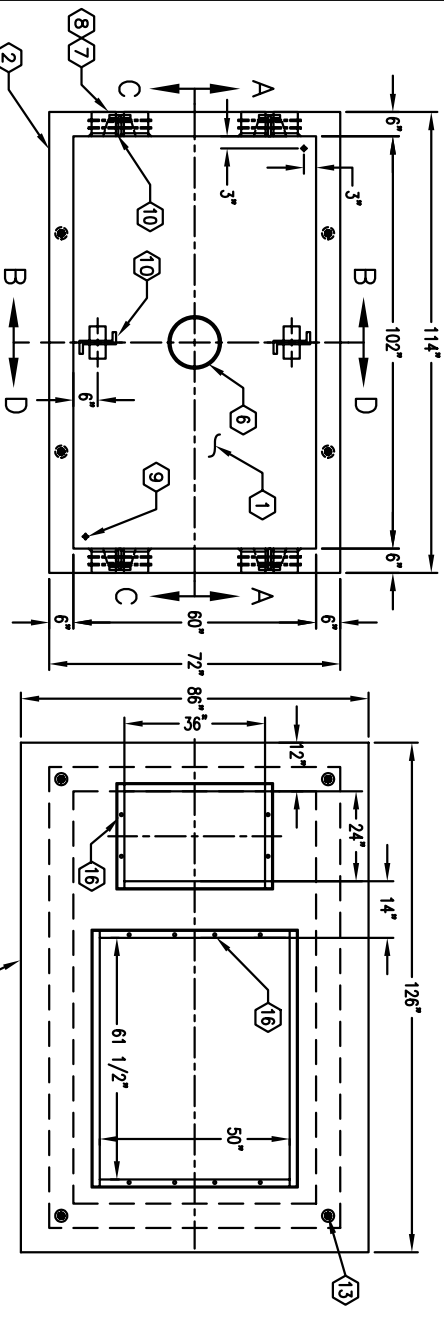
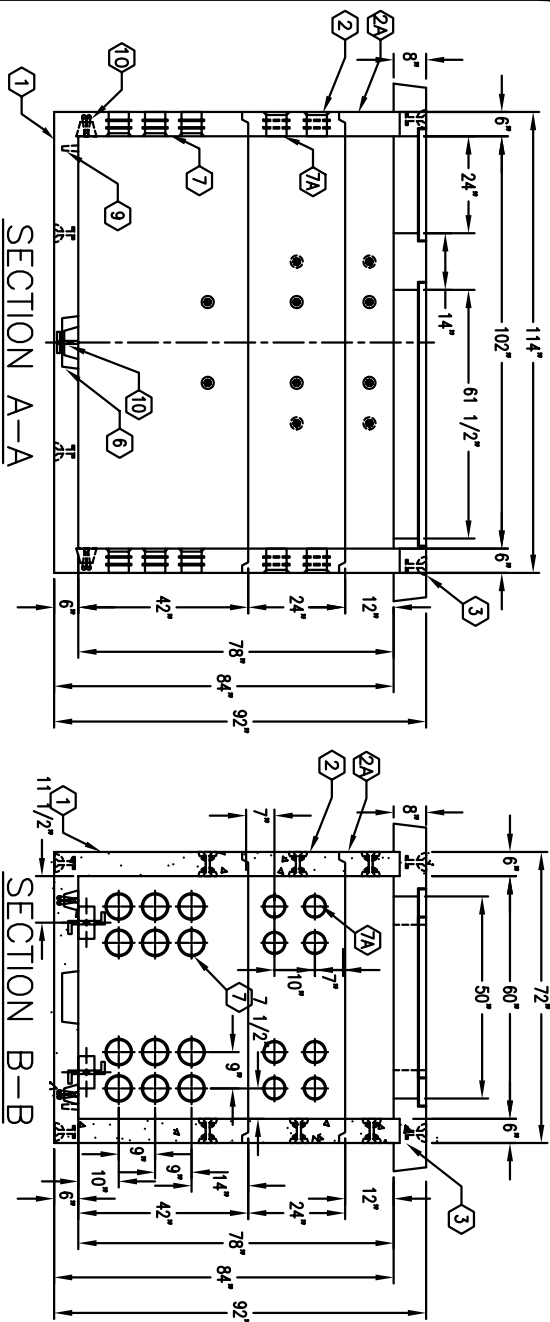

#	DATE	DESCRIPTION	BY
A	10-09-06	CHANGE ITEMS IN BTM SECTION	DRG
B	11-03-06	ADD NOTCH IN PAD.	JK

K586-SB78-25

PER I.L.D. 856-4 Rev.01 07-26-03

12-01-03

