

7'-0" x 14'-0" CITY OF CORONA VAULT x 8'-0" DEEP

MATERIAL LIST-K714-FV96-11				
ITEM	PART NO.	DESCRIPTION	CAGE NO./ LOCATE	WEIGHT/ MOUNT
1	UV714-B48-39	48" BOTTOM SECTION - WITH 6" TERMS.	CG-714-B48-11(12)	25,200 lbs
2	UV714-T48-39	48" TOP SECTION - WITH 6" TERMS.	CG-714-T48-11(13)	25,730 lbs
3		KNOCK OUT	BOTTOM SECTION	(1) CORE
4	55-30-61	6" DIA. CONTERMS	BOTTOM & TOP	(12) CORE
6	55-30-80	10" DIA x 4" DEEP ABS PLASTIC VENT TERMINATORS	TOP SECTION	(2) CORE
7	55-35-06	7/8" DIA. x 6" GALV. VERTICAL PULL IRON	BOTTOM SECTION	(2) CORE
			TOP SECTION	(2) CORE
8	55-10-850	1" GALV. COIL THREADED INSERT	TOP SECTION	(6) CORE
9	55-10-425	1/2" THREADED BRONZE GROUND INSERT WELD TO REBAR "GRD" SHOULD BE STENCILED IN RED LETTERS	BOTTOM SECTION	(2) CORE
			TOP SECTION	(4) CORE
10	55-10-422	1/2" LOOP INSERT	TOP SECTION	(4) CORE
11	55-10-424	1/2" PLASTIC INSERT	BOTTOM SECTION	(18) CORE
			TOP SECTION	(17) CORE

NOTES:

- VAULT DESIGNED IN ACCORDANCE WITH AASHTO HS 20-44 TRAFFIC BRIDGE LOADING USING 5,500 PSI [37.92MPa] COMPRESSIVE STRENGTH CONCRETE AND 60,000 PSI [413.2MPa] YIELD STRENGTH ASTM A-706 STEEL REINFORCEMENT PER CALCS. #31004.
- VAULT TO BE PLACED ON A MIN. 6" BASE OF CRUSHER RUN FOR EASE OF INSTALLATION AND EVEN LOAD DISTRIBUTION.
- LIMIT OF COVER OVER ROOF SECTION IS 1'-6" TO 4'-0".
- ALL WALLS AND CEILINGS SHALL BE PAINTED WHITE.

THE FOLLOWING MATERIAL TO BE SHIPPED WITH THE VAULT

- a) 7/8" x 1 3/4" GASKET (90 FT. REQ'D.)
- b) 1/2" x 2 1/2" S.S.H.H. BOLTS. (18 REQ'D)
- c) 18 HOLE CABLE RACKS (9 REQ'D.)
- d) BOLT 1/2" x 6" J" GALV. (4 REQ'D)

ORDERING INFORMATION:

K714-FV96-39 FOR ASSEMBLY AS SHOWN.
TOTAL WEIGHT OF ASSEMBLY SHOWN AS 50,930 Lbs.

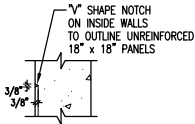
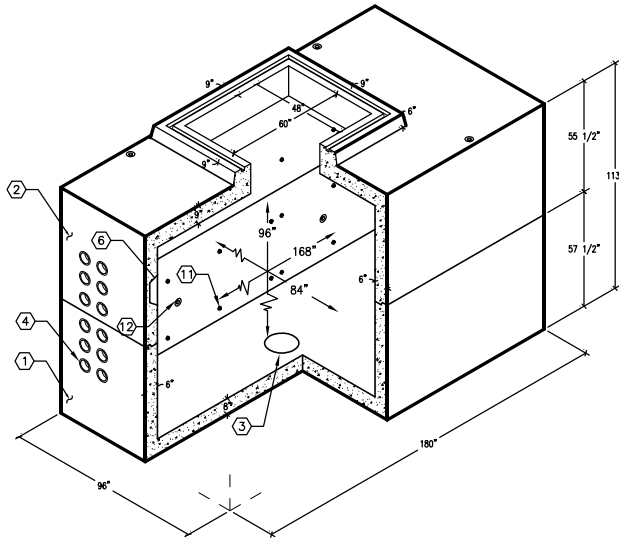

DETAIL 1
(SCALE: 1 1/2" = 1'-0")

MINIMUM EXCAVATION SIZE:
9'-0" x 17'-0" x DEPTH REQ'D.

K714-FV96-39

PER CITY OF CORONA SPEC. 04-23-04

JENSEN PRECAST

AUTOCAD REL. 14

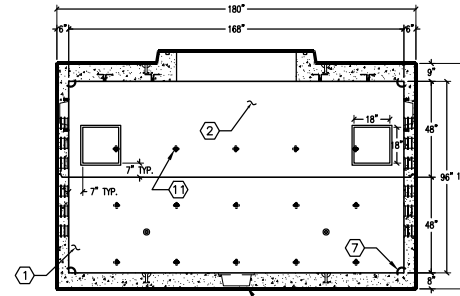

SECTION A-A

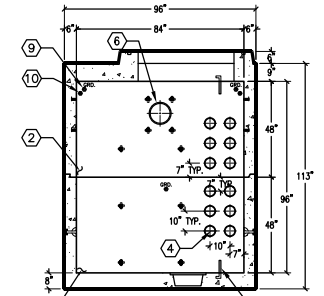

SECTION B-B

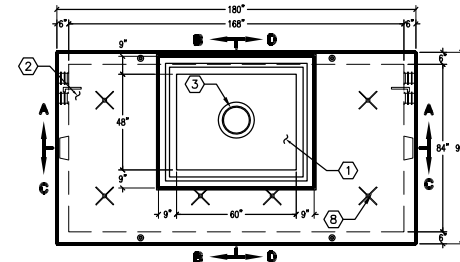

PLAN VIEW

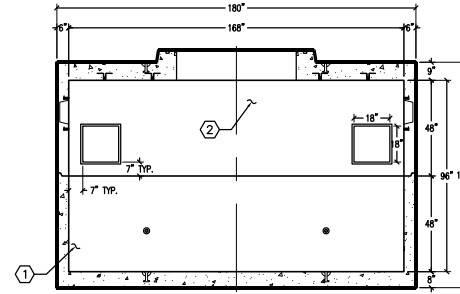

SECTION C-C

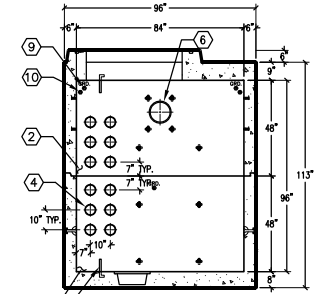

SECTION D-D

JENSEN PRECAST

#	DATE	DESCRIPTION	BY

K714-FV96-39

PER CITY OF CORONA SPEC.