

24"x36" DROP INLET

UP TO 6'-0" INSIDE DEPTH

DROP INLET			
MODEL NO.	A	B	* WEIGHT
DI243636	36"	42"	3028 LBS.
DI243648	48"	54"	3889 LBS.
DI243660	60"	66"	5611 LBS.
DI243672	72"	78"	6472 LBS.

*BOX ONLY

FRAME AND GRATE
ASSEMBLY AVAILABLE
IN TRAFFIC OR
PEDESTRIAN MODELS

LOOSE FRAME
PAVING NOTCH
3" (TRAFFIC)
1-1/2" (PEDESTRIAN)

31" ROUND THIN
WALL KNOCKOUTS.
SLUDGE OUT AS
REQUIRED.
(TYP. 2 PLACES)

18"x31" THIN
WALL KNOCKOUTS.
SLUDGE OUT AS
REQUIRED.
(TYP. 2 PLACES)

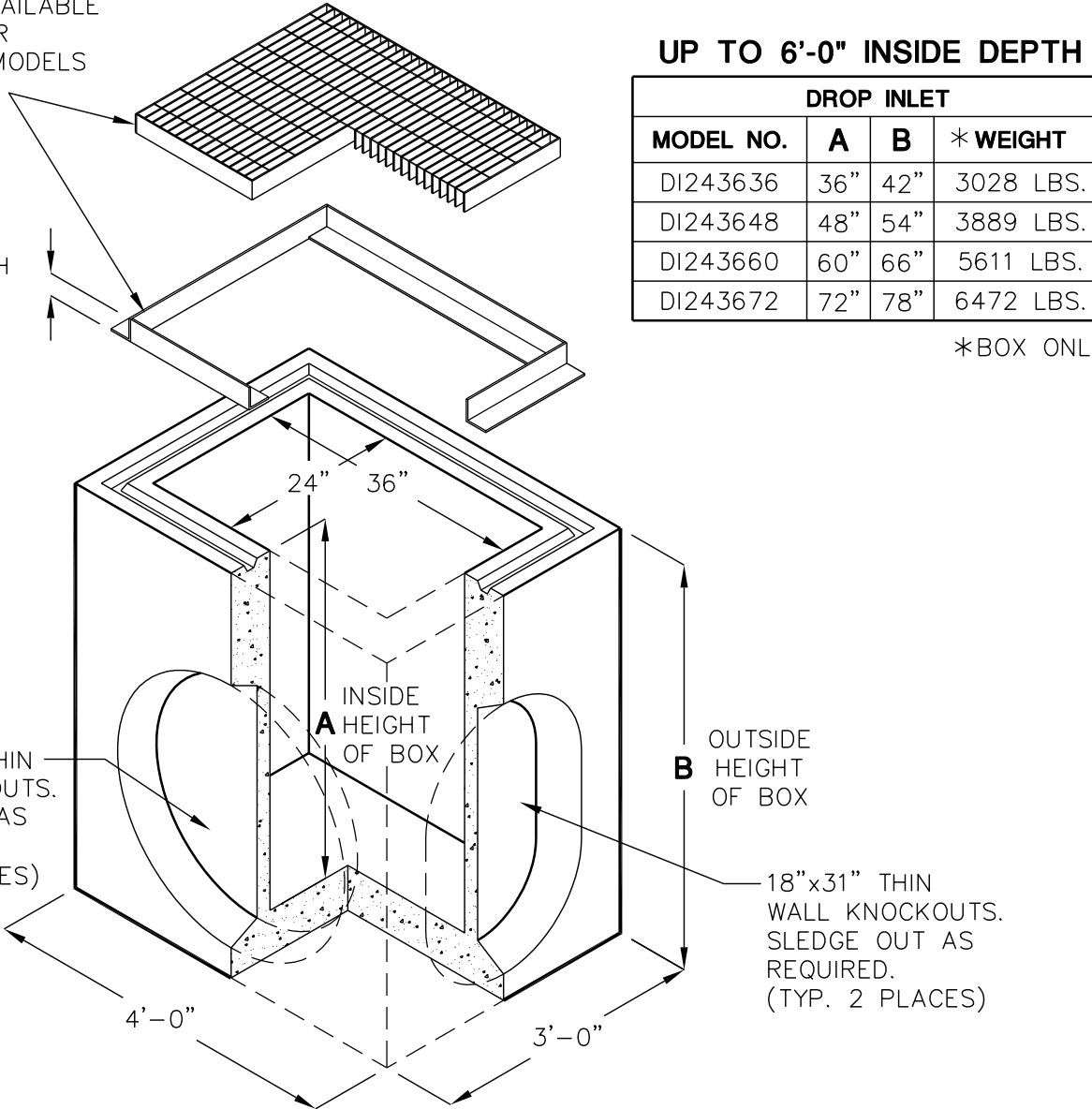

EXTENSION		
MODEL NO.	C	WEIGHT
RS243606	6"	450 LBS.
RS243612	12"	900 LBS.

BOX DESIGN LOAD:
H-20 TRAFFIC

FOR COMPLETE DESIGN
AND PRODUCT INFORMATION,
CONTACT JENSEN PRECAST.