

PUMP AND LIFT STATION DEMAND DOSE-RESIDENTIAL

DESIGNED TO MEET MOST RESIDENTIAL DEMAND DOSE APPLICATIONS. CALL JENSEN PRECAST WITH YOUR TRANSPORT PIPE LENGTH, SIZE, AND LIFT TO VERIFY PUMP SELECTION.

300 GPD BIOTUBE® EASYPAK™
PUMP PACKAGE

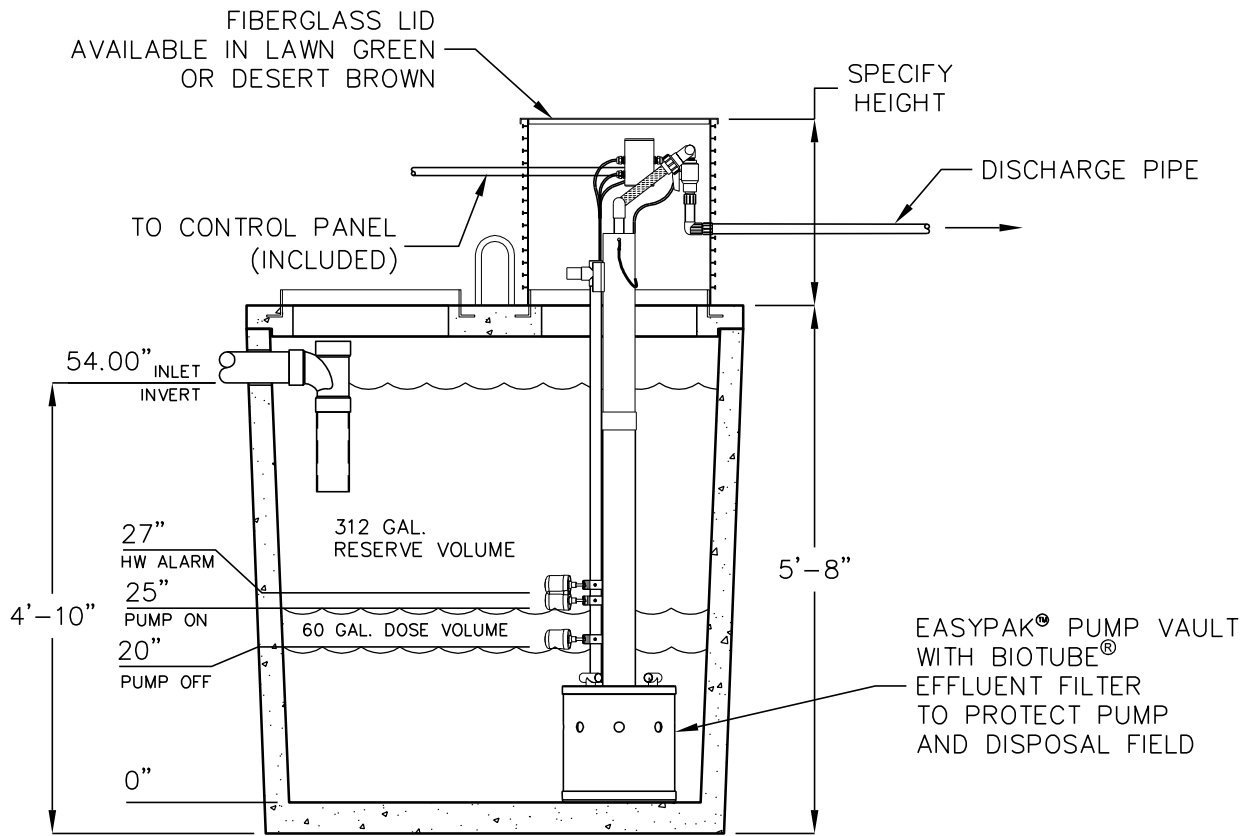

ELEVATION SECTION

- 4" TURBINE EFFLUENT PUMP, WITH 5 YEAR WARRANTY, LASTS FOUR TIMES LONGER THAN CENTRIFUGAL PUMPS.
- FLOATS CAN BE EASILY ADJUSTED TO CHANGE DOSE VOLUME.
- SIMPLEX ELECTRO-MECHANICAL CONTROL PANEL WITH AUDIO AND VISUAL ALARM.
- POWER REQUIREMENTS: 120 VOLT, SINGLE PHASE AT 60 HZ.
- 12 GALLONS PER VERTICAL INCH.
- DESIGN LOAD: NON-TRAFFIC WITH 3 FOOT MAXIMUM SOIL COVER WITH WATER TABLE BELOW BOTTOM OF STRUCTURE. TRAFFIC RATED DESIGNS ARE AVAILABLE.
- FOR COMPLETE DESIGN AND PRODUCT INFORMATION CONTACT JENSEN PRECAST.

MODEL	DISCHARGE	MAX FLOW RATE
PAS500-300-10DD	STANDARD	10
PAS500-300-10DD-DB	DRAIN BACK*	10
PAS500-300-10DD-CW	COLD WEATHER	10
PAS500-300-15DD	STANDARD	15
PAS500-300-15DD-DB	DRAIN BACK*	15
PAS500-300-15DD-CW	COLD WEATHER	15
PAS500-300-20DD	STANDARD	20
PAS500-300-20DD-DB	DRAIN BACK*	20
PAS500-300-20DD-CW	COLD WEATHER	20

*ADJUST DOSE VOLUME TO INCLUDE TRANSPORT PIPE VOLUME

BIOTUBE® AND EASYPAK® ARE TRADEMARKS OF ORENCO SYSTEMS, INC.

Jensen Precast reserves the right to make changes to product design and/or dimensions without notice. Please contact Jensen Precast whenever necessary for confirmation or advice on product design.

JENSEN
PRECAST