

1200 GALLON GREASE INTERCEPTOR

MODEL JP1200EE-G
ACCEPTED BY UPC[®]

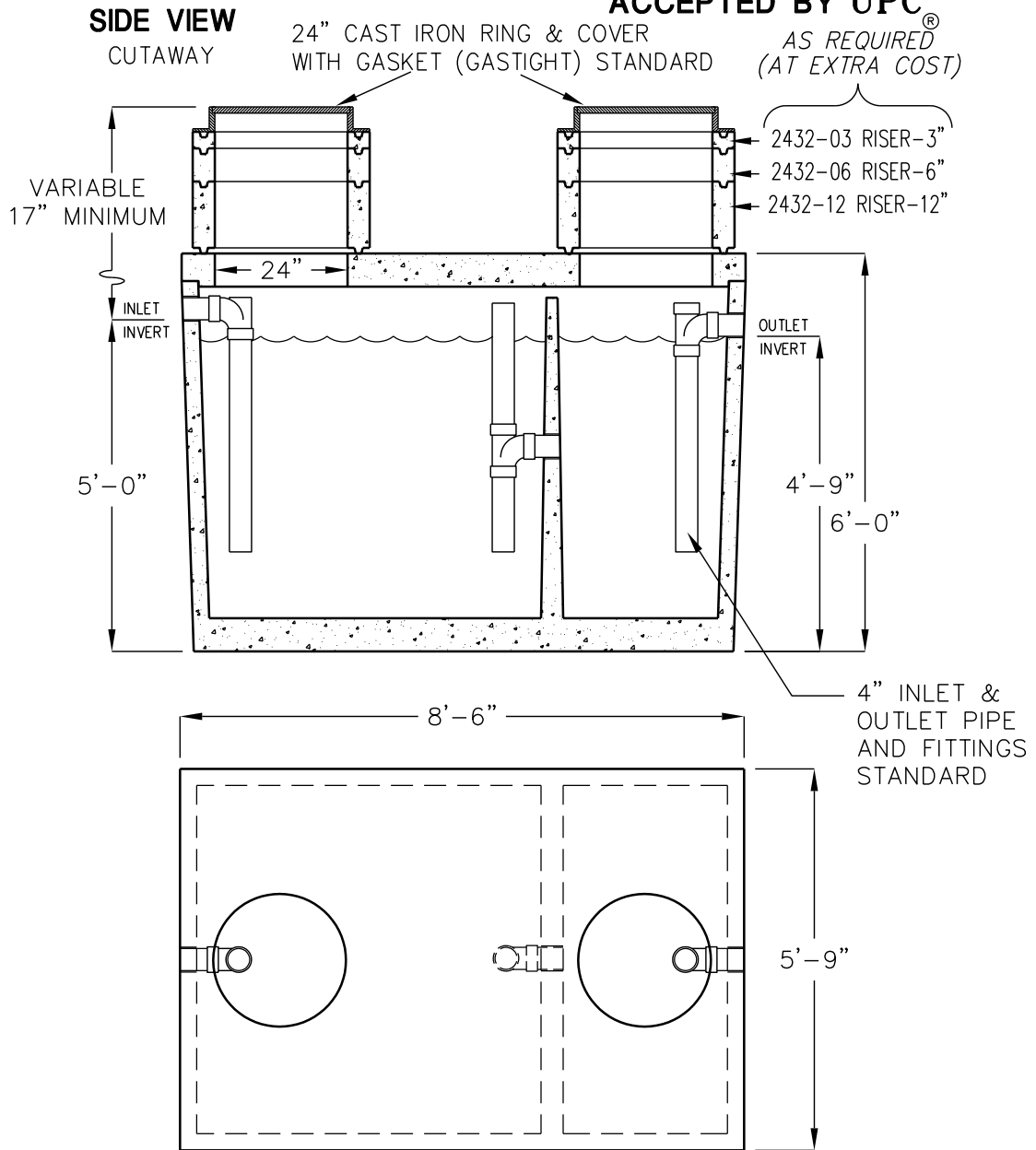

LIQUID CAPACITY: 1,200 GALLONS.

BOX DESIGN LOAD: H-20 TRAFFIC FROM
1' TO 6' OF SOIL COVER.

FOR COMPLETE DESIGN AND PRODUCT
INFORMATION CONTACT JENSEN PRECAST.