

3,000 GALLON CLARIFIER

MODEL JZ3000-ECE-CL
TRAFFIC RATED

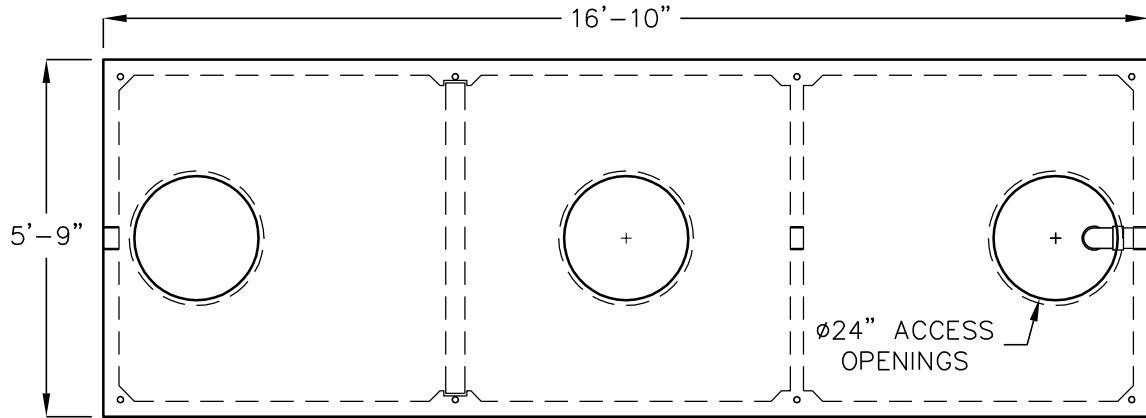

PLAN VIEW

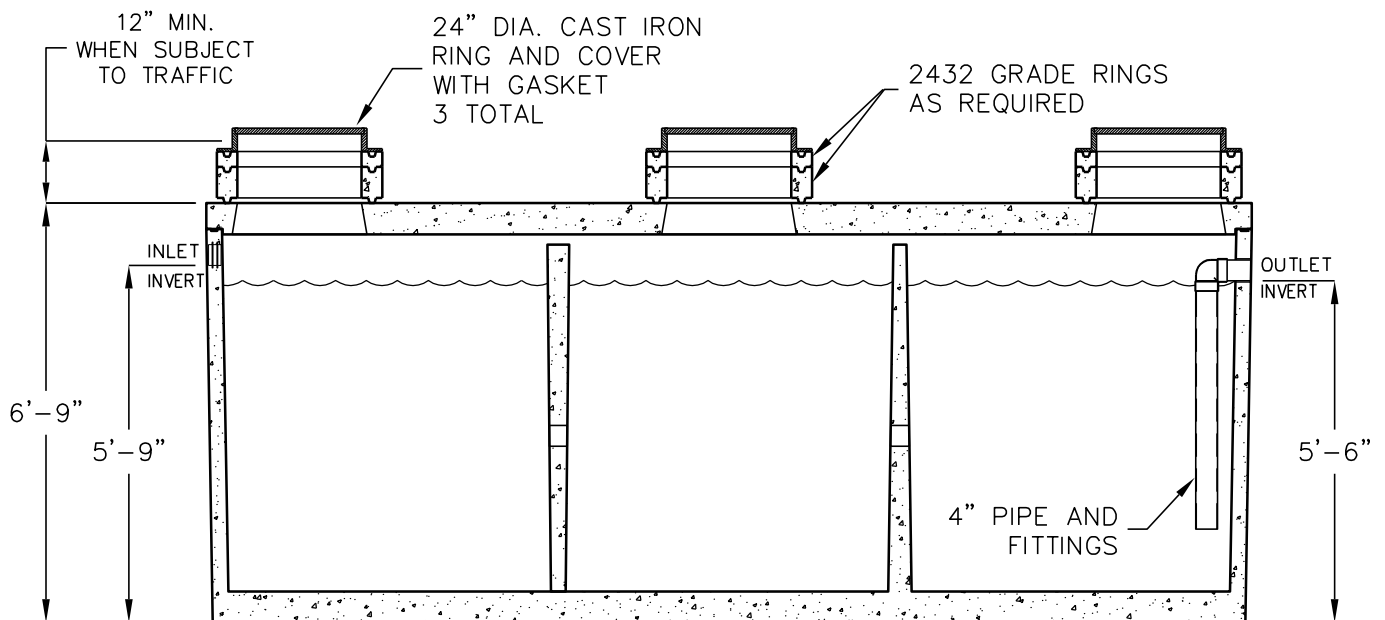

ELEVATION SECTION

OPERATING CAPACITY: 3,000 GALLONS.

DESIGN LOAD: H-20 TRAFFIC WITH DRY SOIL CONDITIONS (WATER LEVEL BELOW TANK) AND 1 TO 6 FEET EARTH COVER.

BEDDING NOTE: SUITABLE SUB-BASE BEDDED WITH GRANULAR MATERIAL SHALL BE PREPARED TO HANDLE ANTICIPATED LOADS.

FOR COMPLETE DESIGN AND PRODUCT INFORMATION
CONTACT JENSEN PRECAST.

MINIMUM EXCAVATION
6'-9" x 17'-10"
x REQ'D DEPTH

Jensen Precast reserves the right to make changes to product design and/or dimensions without notice. Please contact Jensen Precast whenever necessary for confirmation or advice on product design.

JENSEN
PRECAST