

# NO. 9 PULLBOX

3'-6"x3'-6"x3'-2"  
(NOMINAL INSIDE DIMENSIONS)  
CITY OF PHOENIX  
PB9-PHO

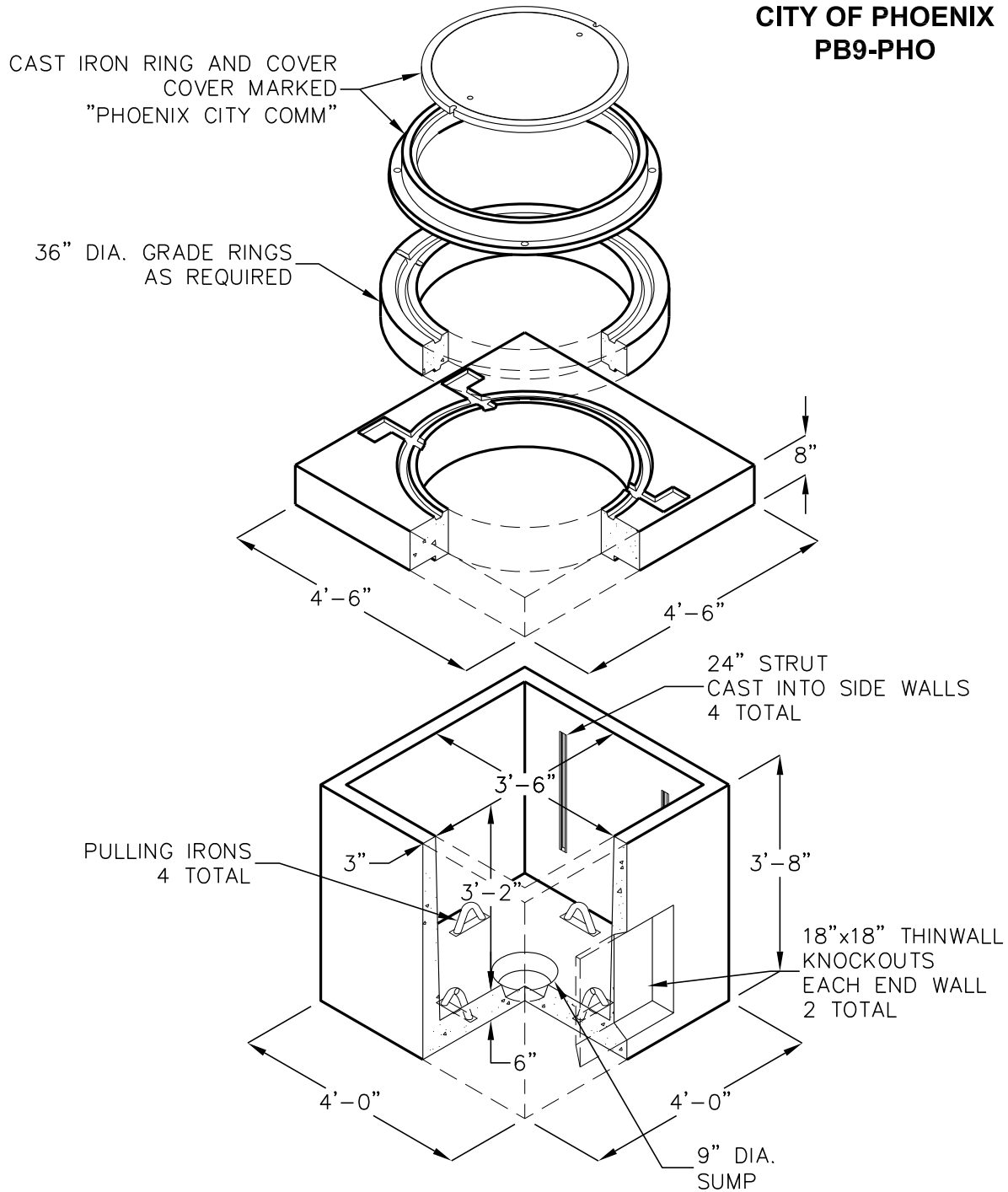

DESIGN LOAD: H-20 TRAFFIC.

WATER TABLE ASSUMED TO BE BELOW STRUCTURE.

FOR COMPLETE DESIGN AND PRODUCT INFORMATION CONTACT JENSEN PRECAST.