

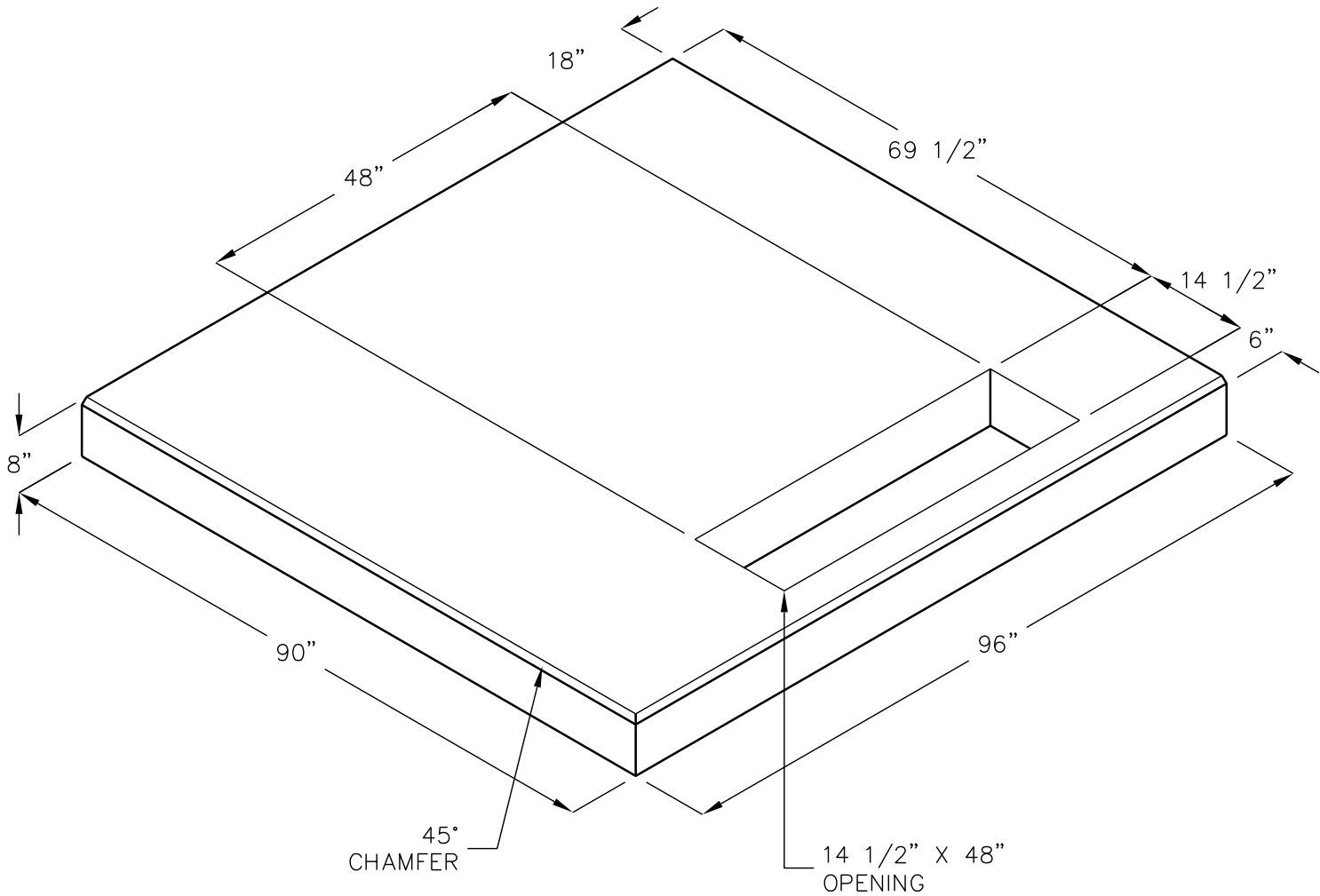

TEP SR-233 'B' TRANSFORMER PAD

750-2500 KVA

DWG. # SR-233 'B'



APPROX. WEIGHT: 5,550 LBS.

FOR COMPLETE DESIGN
AND PRODUCT INFORMATION
CONTACT JENSEN PRECAST.