

615-12

6'-0"x15'-0"x12'-0"
(NOMINAL INSIDE DIMENSIONS)

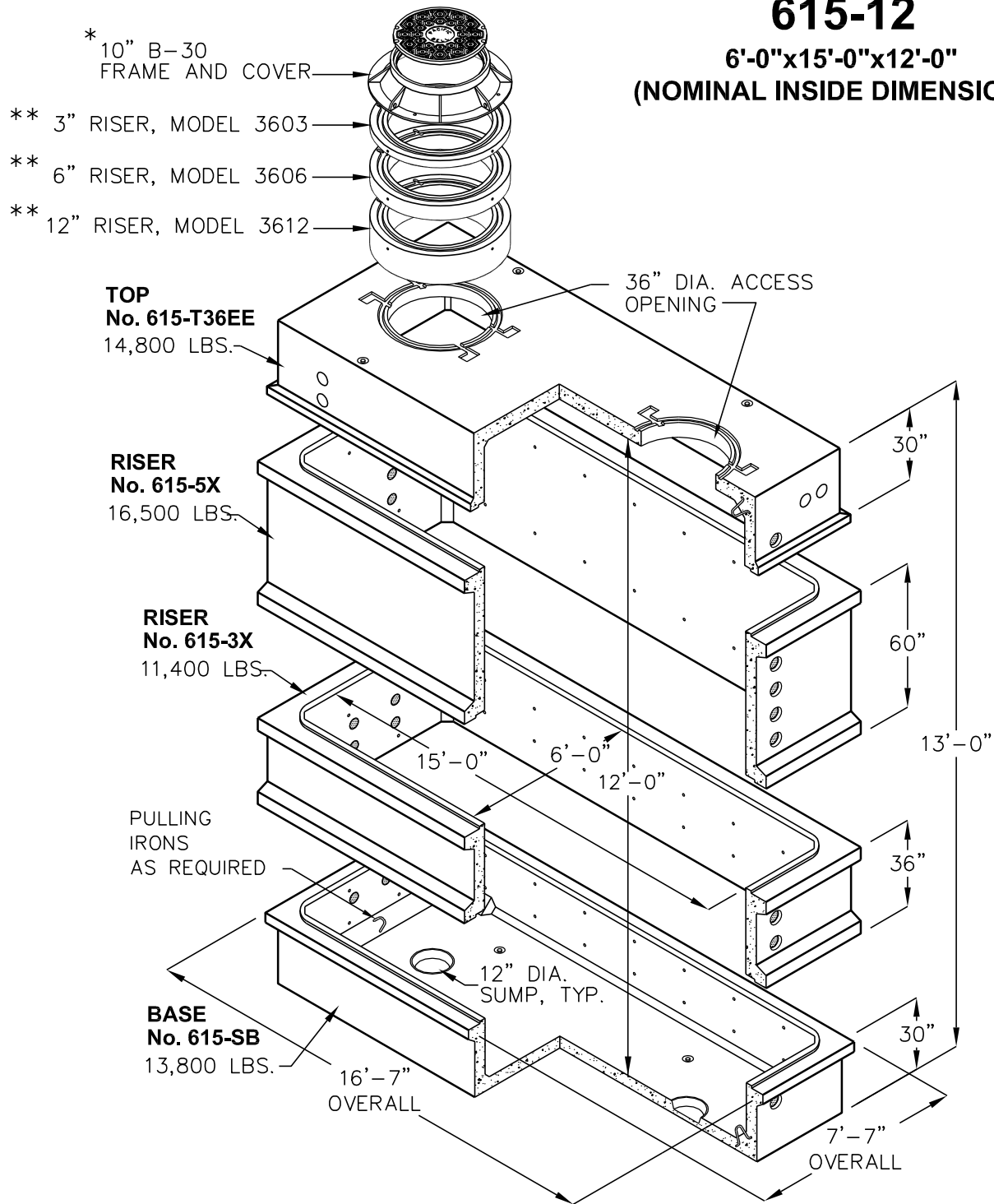

KNOCKOUTS, DUCT TERMINATORS, RACKING,
AND LADDER PER CURRENT SPECIFICATIONS.

DESIGN LOAD: H-20 FULL TRAFFIC

FOR COMPLETE DESIGN AND PRODUCT INFORMATION
CONTACT JENSEN PRECAST.

* SEE HARDWARE/APPERTENANCES SECTION
FOR SPECIFICATIONS.

**RISERS OPTIONAL- SEE COLLAR/RISER
SECTION FOR SPECIFICATIONS.

Jensen Precast reserves the right to make changes to product design
and/or dimensions without notice. Please contact Jensen Precast whenever
necessary for confirmation or advice on product design.

JENSEN
PRECAST