

ACCESS COVERS

ADJUSTABLE TORSION SPRING ASSISTED

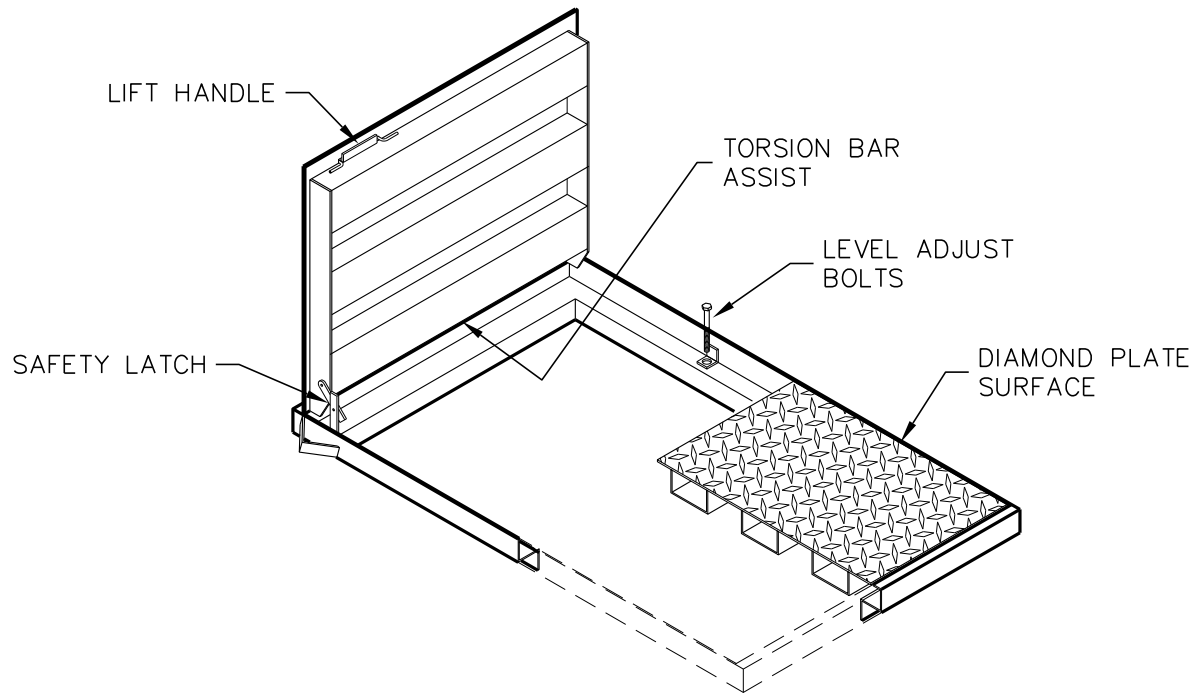

MODEL NUMBER	CONCRETE OPENING	
	WIDTH	LENGTH
2424AT	24"	24"
2436AT	24"	36"
3048AT	30"	48"
3636AT	36"	36"
3660AT	36"	60"
3672AT	36"	72"
4266AT	42"	66"
4848AT	48"	48"
4878AT	49"	79"
6060AT	60"	60"

TRAFFIC MODELS

DESIGNED FOR INCIDENTAL H-20 WHEEL LOADING NOT RECOMMENDED FOR IN STREET USE OR HIGH DENSITY TRAFFIC. OTHER LOAD CRITERIA AVAILABLE ON REQUEST.

NON TRAFFIC MODELS

DESIGNED FOR 300 PSF PEDESTRIAN LOADING.

AVAILABLE OPTIONS (AT EXTRA COST)

- CUSTOM SIZES
- SAND EPOXY FINISH
- HOT DIP GALVANIZING
- NON-SLIP SURFACE
- RECESSED PADLOCK HASP
- SAFETY BAR
- TAMPER RESISTANT BOLTS
- DIAMOND PLATE STEEL OR ALUMINUM

FOR COMPLETE DESIGN AND PRODUCT INFORMATION CONTACT JENSEN PRECAST.

Jensen Precast reserves the right to make changes to product design and/or dimensions without notice. Please contact Jensen Precast whenever necessary for confirmation or advice on product design.