

FOR VEHICLE CONTROL AND CONSTRUCTION SITE SAFETY

- Reduce Crossover Accidents
- Reduce Liability Exposure
- Reduce Vehicle Damage
- Reduce Traffic Fatalities

SPECIFICATIONS

- Approximate Weight per Panel: 10'–3,900 lb. (1,770 kg.), 20'–7,800 lb. (3,540 kg.)
- Laying Length per Panel: 10'–0" (3m), 20'–0" (6m)

OPTIONS

- End Loops for Pin Connection
- "Gawk" Screen Holes
- Fence Post Holes
- Lifting Devices
- Colored Concrete
- Fork Lift Pockets
- Scuppers

OTHER USES

- Excavation Enclosure
- Material Storage
- Retaining Wall
- Barricades
- Security

10' (3m) AND 20' (6m) BARRIER RAIL

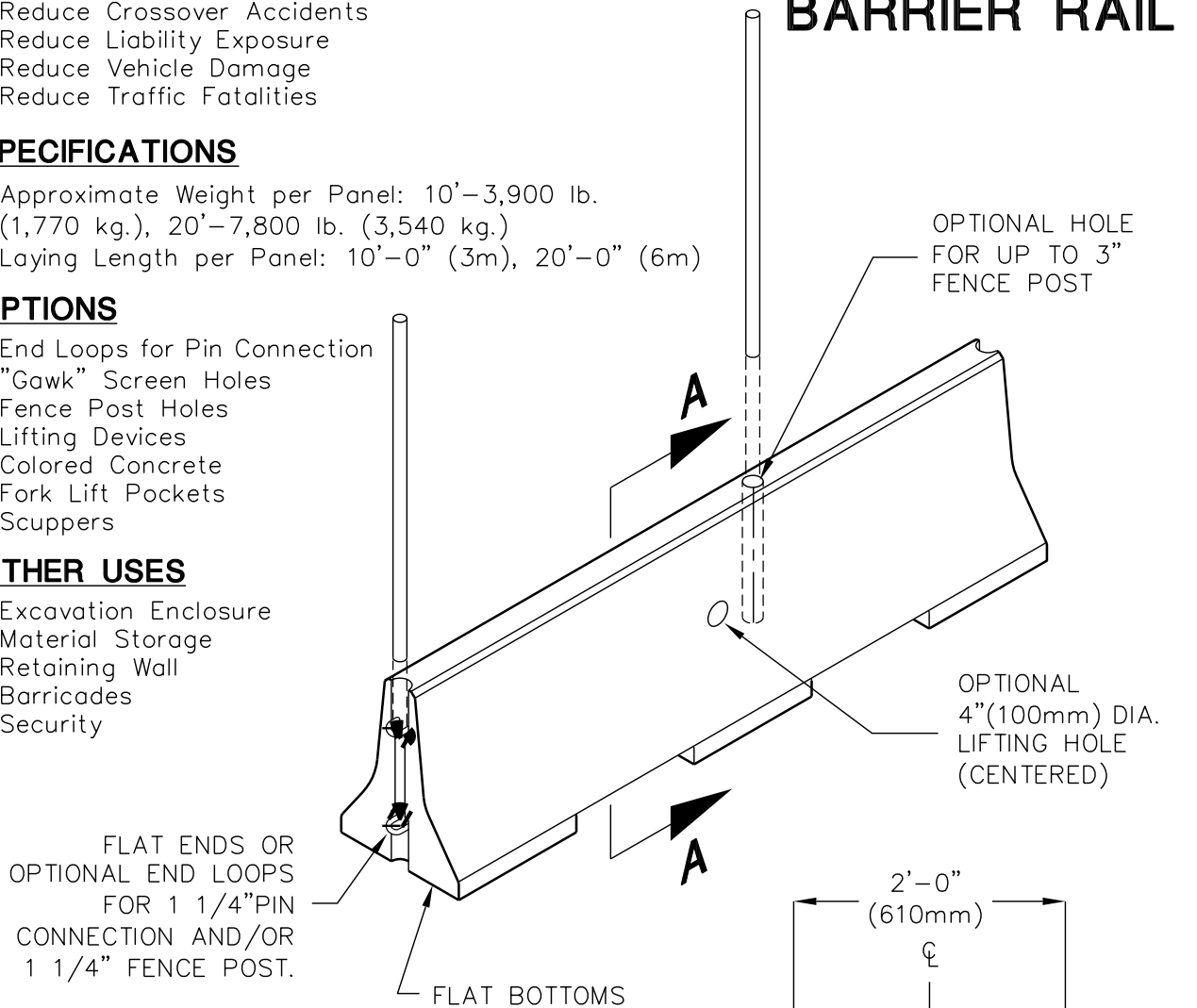

PRECAST CONCRETE BARRIER RAILS IDEALLY SUITED FOR STREET CLOSURES, DETOURS AND CONSTRUCTION SITES. 10ft. OR 20ft. LONG BARRIERS ARE AVAILABLE FOR SALE OR RENTAL ON A SHORT OR LONG DURATION BASIS.

NOTE: METRIC DIMENSIONS ROUNDED TO NEAREST 5mm.

FOR COMPLETE DESIGN AND PRODUCT INFORMATION, CONTACT JENSEN PRECAST.

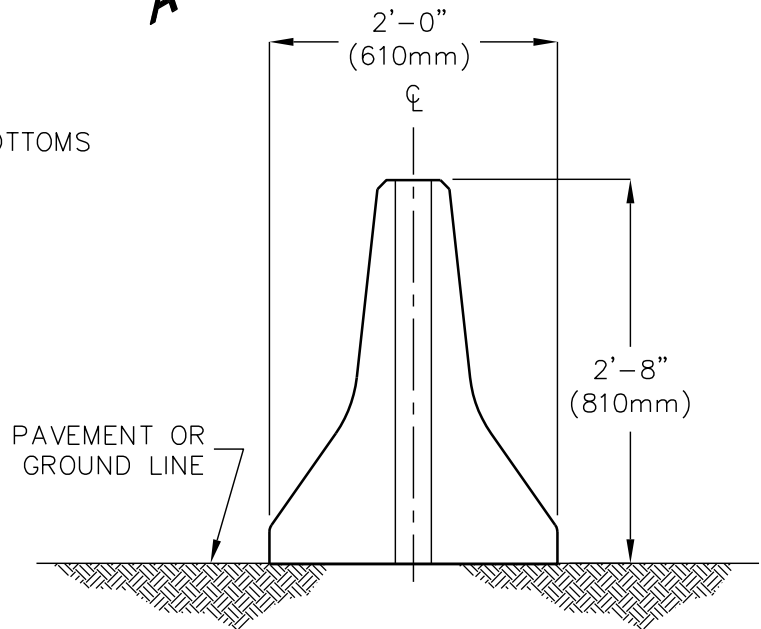

SECTION A-A