

# GTE69 MANHOLE

## MEETS GTE SPECIFICATIONS

MODEL NUMBER	A	B	GTE ITEM
GTE-69-14	14'	15'	180000
GTE-69-19	19'	20'	180000
GTE-69-24	24'	25'	180000

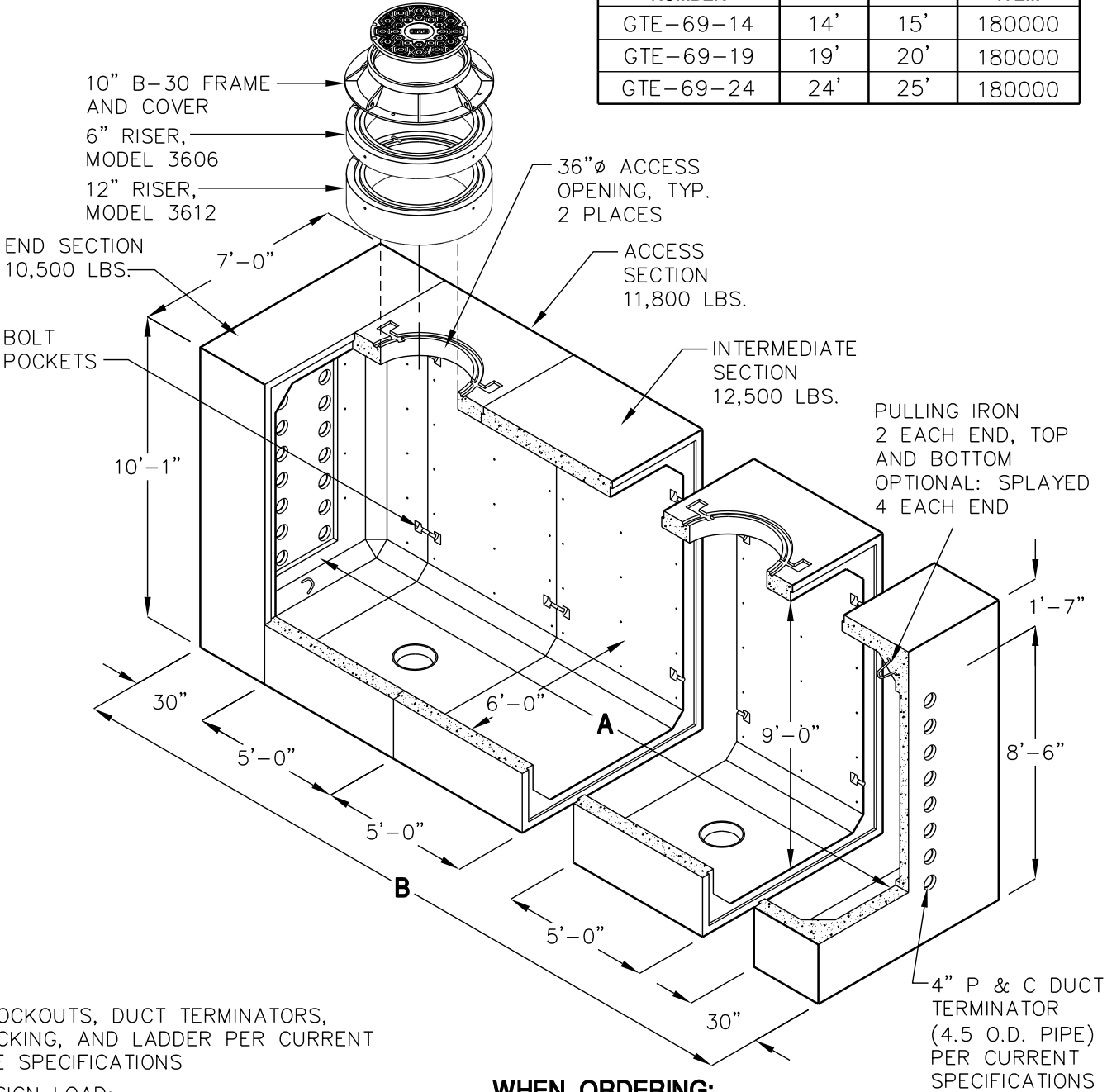

KNOCKOUTS, DUCT TERMINATORS, RACKING, AND LADDER PER CURRENT GTE SPECIFICATIONS

DESIGN LOAD:  
H-20 TRAFFIC  
WITH 1' TO 5' EARTH COVER

FOR COMPLETE DESIGN  
AND PRODUCT INFORMATION,  
CONTACT JENSEN PRECAST.

**WHEN ORDERING:**

THE STANDARD GTE69 KIT INCLUDES:  
2 END SECTIONS. 2 INTERMEDIATE SECTIONS WITH  
36"Ø ACCESS OPENING. TWO B-30 COVERS,  
TWO 6" GRADE RINGS AND TWO 12" GRADE RINGS,  
TWO LADDERS, 6 STEP RUNGS, RACKING, AND  
BOLT ASSEMBLY.

