

# HIGH CAPACITY CURB INLET 6060-X4 (L OR R)

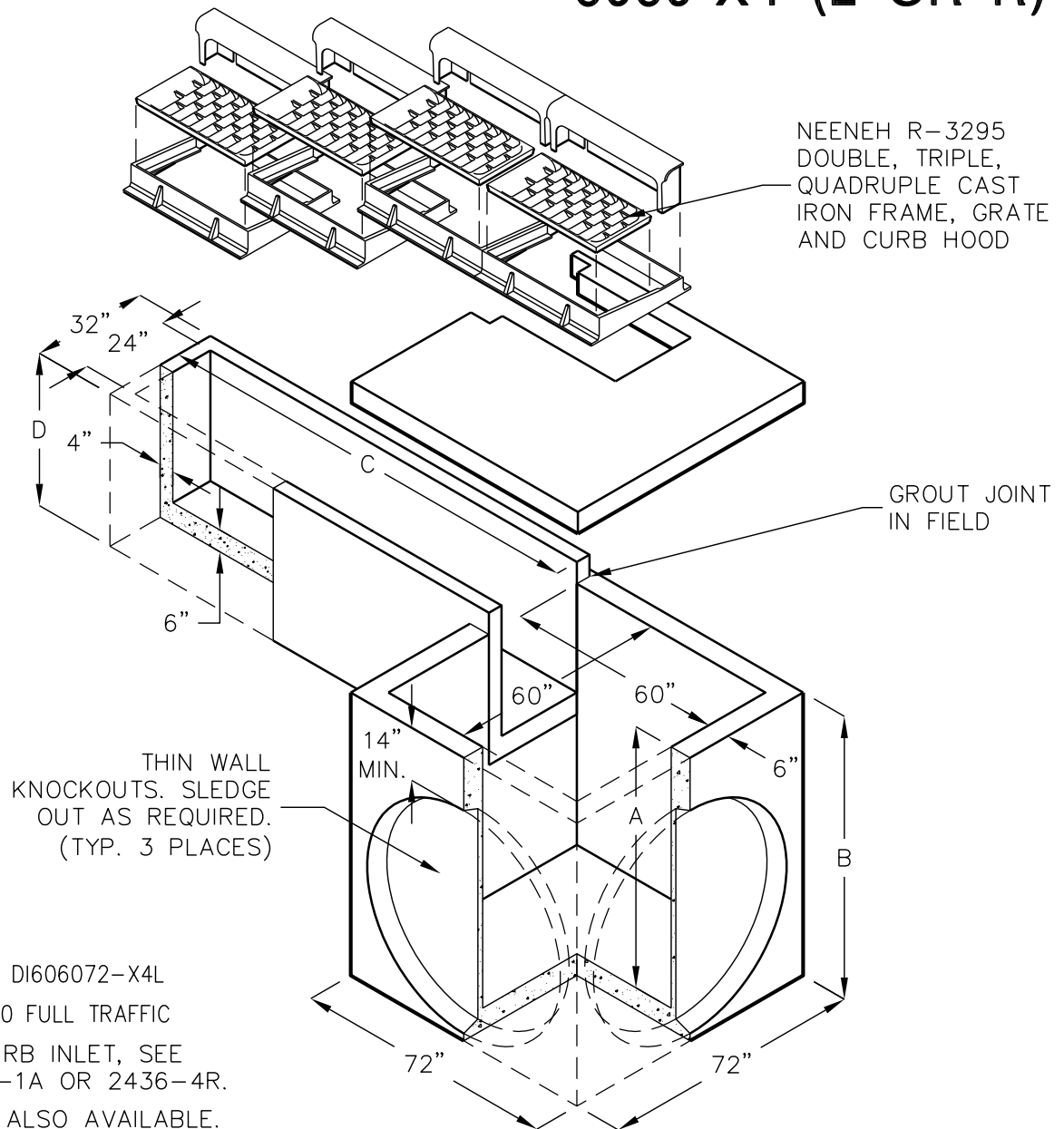

Model No.			Dimensions	
DI Model	Model Suffix	Left or Right	A	B
DI606036-	X2 ,X3, X4	L OR R (LEFT SHOWN)	36"	42"
DI606048-			48"	54"
DI606060-			60"	66"
DI606072-			72"	78"

Model Suffix	No. of Grates	Dimensions	
		C	D
X2	2	41 1/2"	36"
X3	3	79"	48"
X4	4	116 1/2"	60"

FOR COMPLETE DESIGN  
AND PRODUCT INFORMATION,  
CONTACT JENSEN PRECAST.