

JP-3000 BATTERY SERIES COMMERCIAL LOW PROFILE SEPTIC TANKS

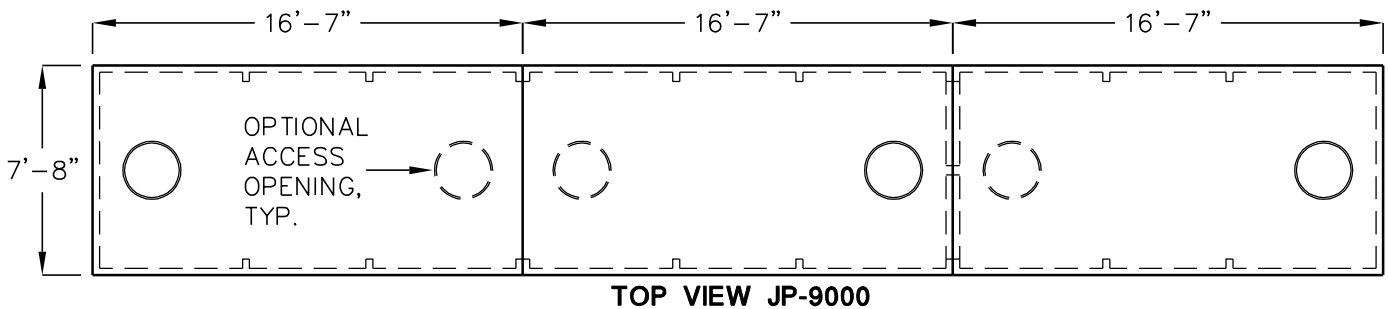
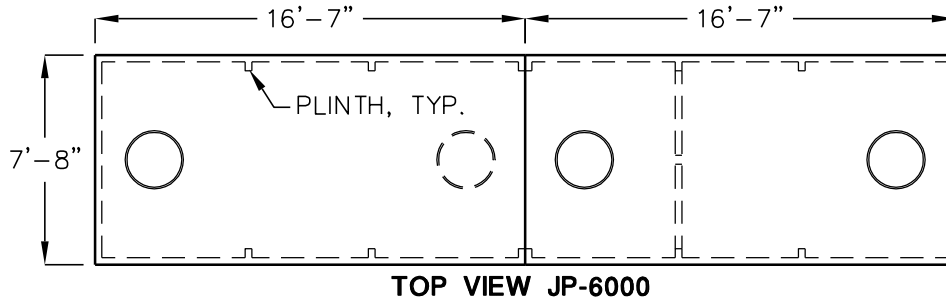
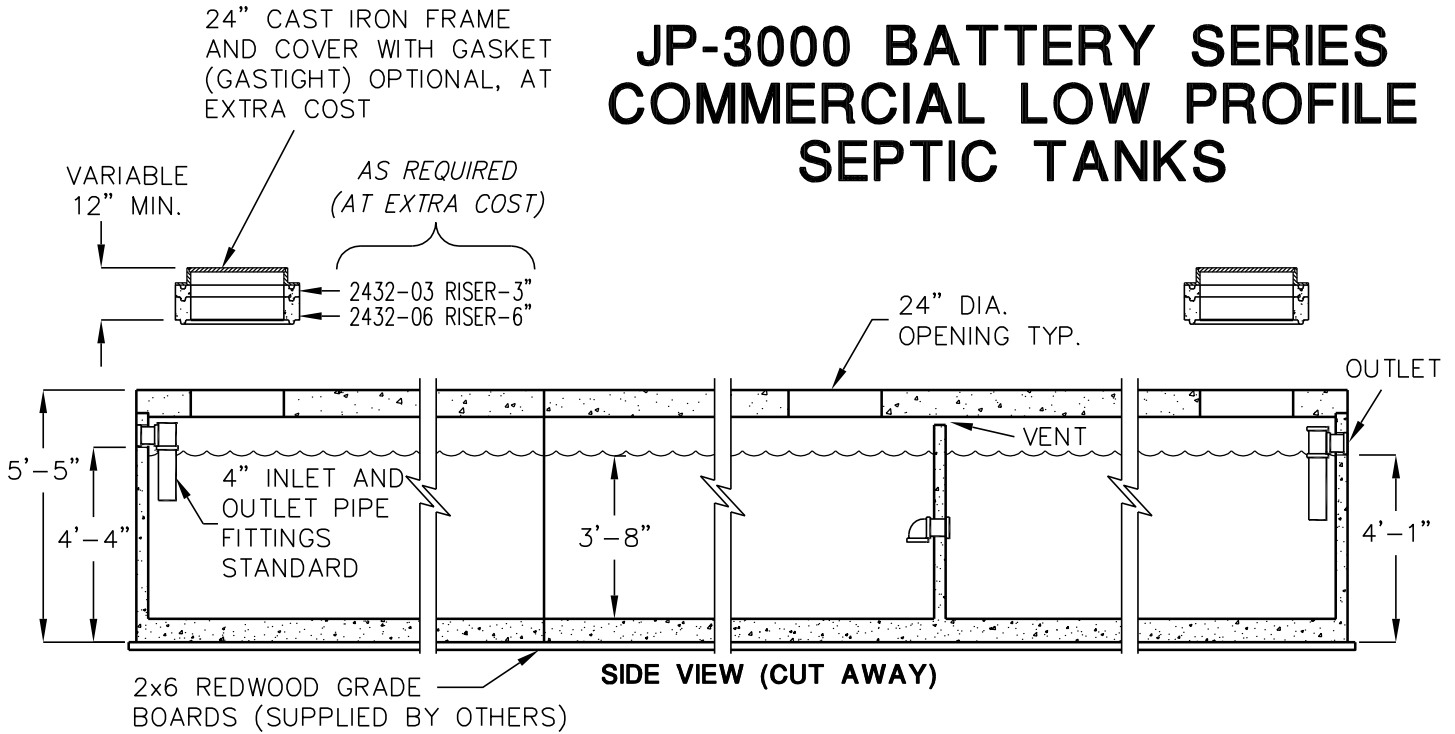

MODEL NO.	SECTIONS	INSTALLATION LENGTH	LIQUID CAPACITY
2xJP-3000	2 JP-3000 BATTERY TANKS	33'-4"	6000 GALLONS
3xJP-3000	3 JP-3000 BATTERY TANKS	50'-1"	9000 GALLONS
4xJP-3000	4 JP-3000 BATTERY TANKS	66'-10"	12000 GALLONS
5xJP-3000	5 JP-3000 BATTERY TANKS	83'-7"	15000 GALLONS

BOX DESIGN LOAD: H-20 TRAFFIC WITH 1' TO 5' OF COVER.
FOR COMPLETE DESIGN AND PRODUCT INFORMATION, CONTACT JENSEN PRECAST

**DRAWING IS
NOT TO SCALE**