

500 GALLON SAND-OIL INTERCEPTOR

MODEL JP500EE-SO
LISTED BY UPC®

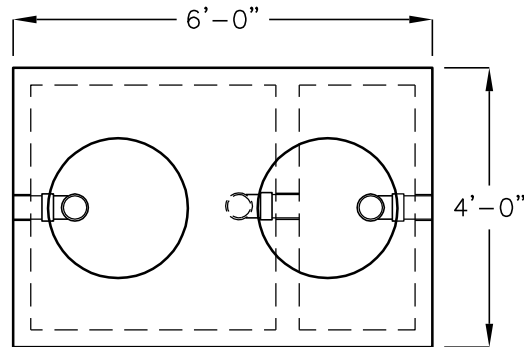

TOP VIEW
(COVERS & RINGS REMOVED)

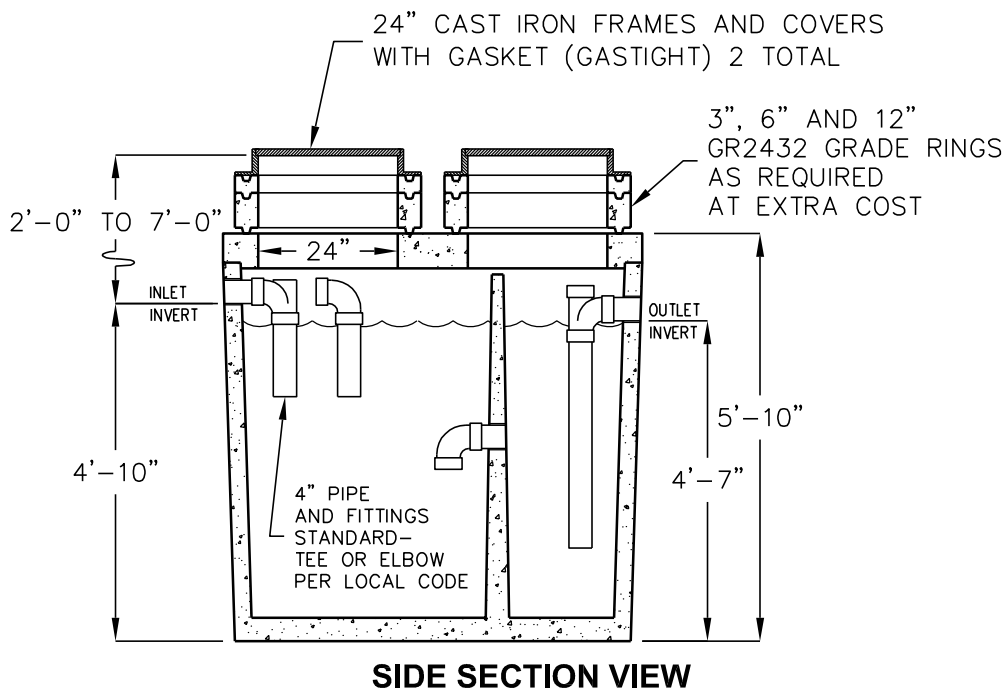

SIDE SECTION VIEW

OPERATING CAPACITY: 500 GALLONS.

DESIGN LOAD: H-20 TRAFFIC WITH DRY SOIL CONDITIONS
(WATER LEVEL BELOW TANK) AND 1'-6" EARTH COVER.

SUITABLE SUB-BASE BEDDED WITH GRANULAR MATERIAL SHALL BE
PREPARED TO HANDLE ANTICIPATED LOADS.

FOR COMPLETE DESIGN AND PRODUCT INFORMATION
CONTACT JENSEN PRECAST.

<p>MINIMUM EXCAVATION 5'-0" x 7'-0" x REQ'D DEPTH</p>
