

**FOR VEHICLE CONTROL AND
CONSTRUCTION SITE SAFETY**

- Reduce Crossover Accidents
- Reduce Liability Exposure
- Reduce Vehicle Damage
- Reduce Traffic Fatalities

SPECIFICATIONS

- Approximate Weight per 10' Panel: 3,900 lb. (1,770 kg.)
20' Panel: 7,800 lb. (3,540 kg.)
- Laying Length per Panel: 10'-0" (3m), 20'-0" (6m)

OPTIONS

- End Loops for Pin Connection
- "Gawk" Screen Holes
- Fence Post Holes
- Lifting Devices
- Colored Concrete
- Fork Lift Pockets
- Scuppers

OTHER USES

- Excavation Enclosure
- Material Storage
- Retaining Wall
- Barricades
- Security

BARRIER RAIL

10'-0" & 20'-0"

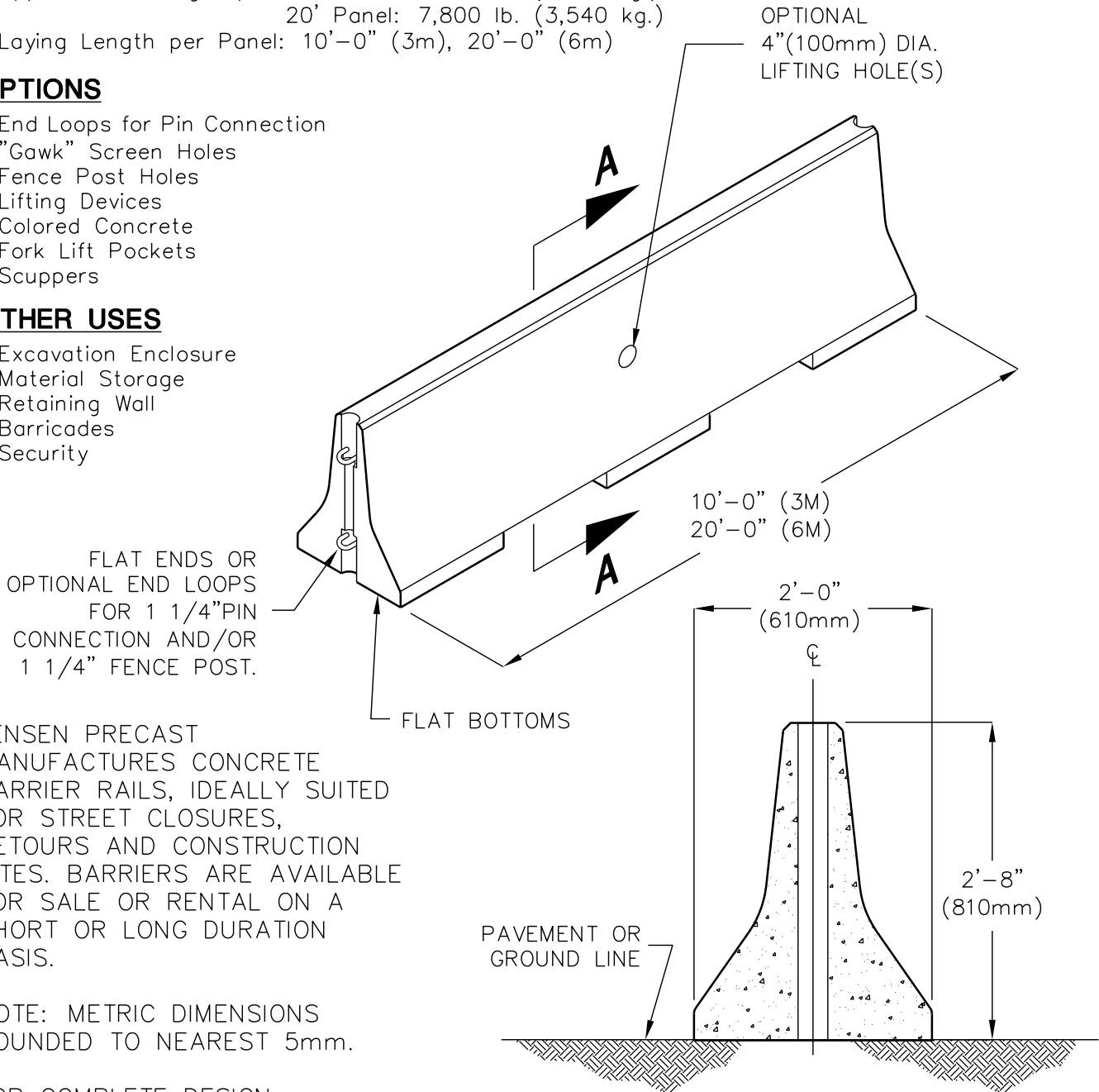

SECTION A-A

JENSEN PRECAST MANUFACTURES CONCRETE BARRIER RAILS, IDEALLY SUITED FOR STREET CLOSURES, DETOURS AND CONSTRUCTION SITES. BARRIERS ARE AVAILABLE FOR SALE OR RENTAL ON A SHORT OR LONG DURATION BASIS.

NOTE: METRIC DIMENSIONS ROUNDED TO NEAREST 5mm.

FOR COMPLETE DESIGN AND PRODUCT INFORMATION, CONTACT JENSEN PRECAST.