

# JUNCTION ENCLOSURE PAD

TRUCKEE DONNER PUBLIC UTILITY DISTRICT  
MODEL TD25L

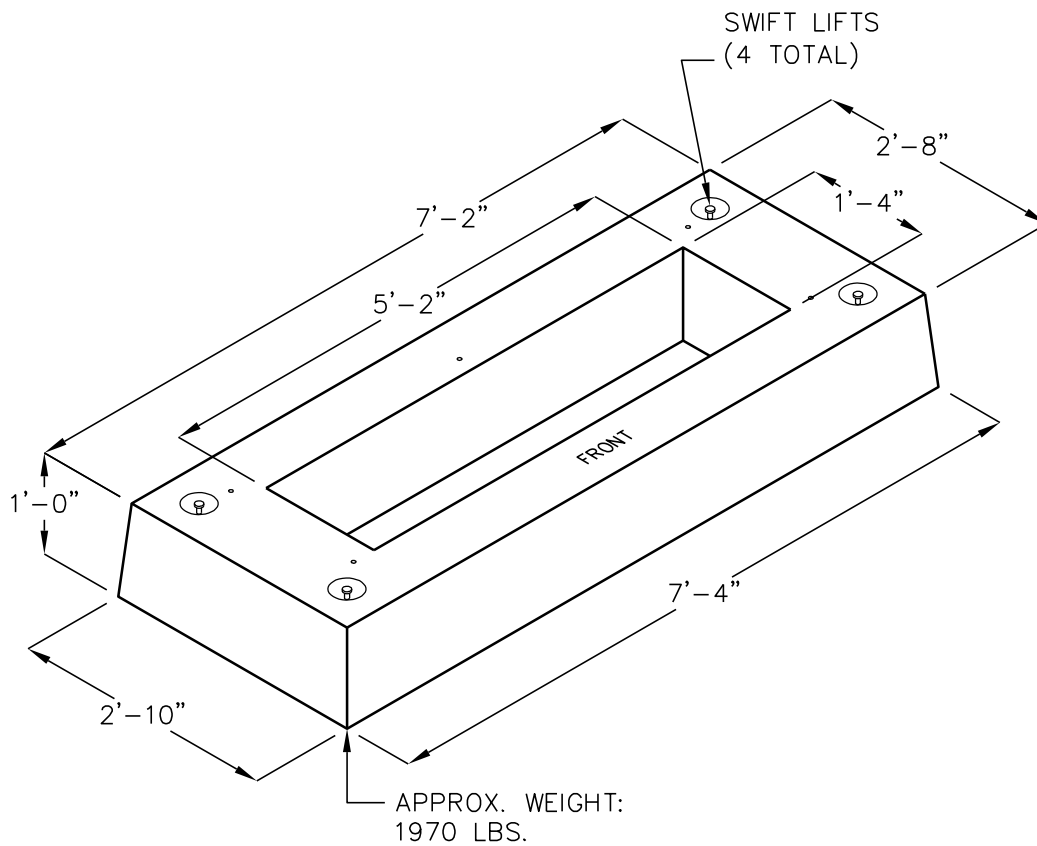

FOR COMPLETE DESIGN AND PRODUCT INFORMATION  
CONTACT JENSEN PRECAST.

1/5/2009  
25L ENCL0S PAD\_TDPUD\_C.DWG  
© 2009

Jensen Precast reserves the right to make changes to product design  
and/or dimensions without notice. Please contact Jensen Precast whenever  
necessary for confirmation or advice on product design.

**JENSEN**  
PRECAST