

# 12,000 GALLON BATTERY SAND-OIL INTERCEPTOR MODEL 3XJZ4000-SO

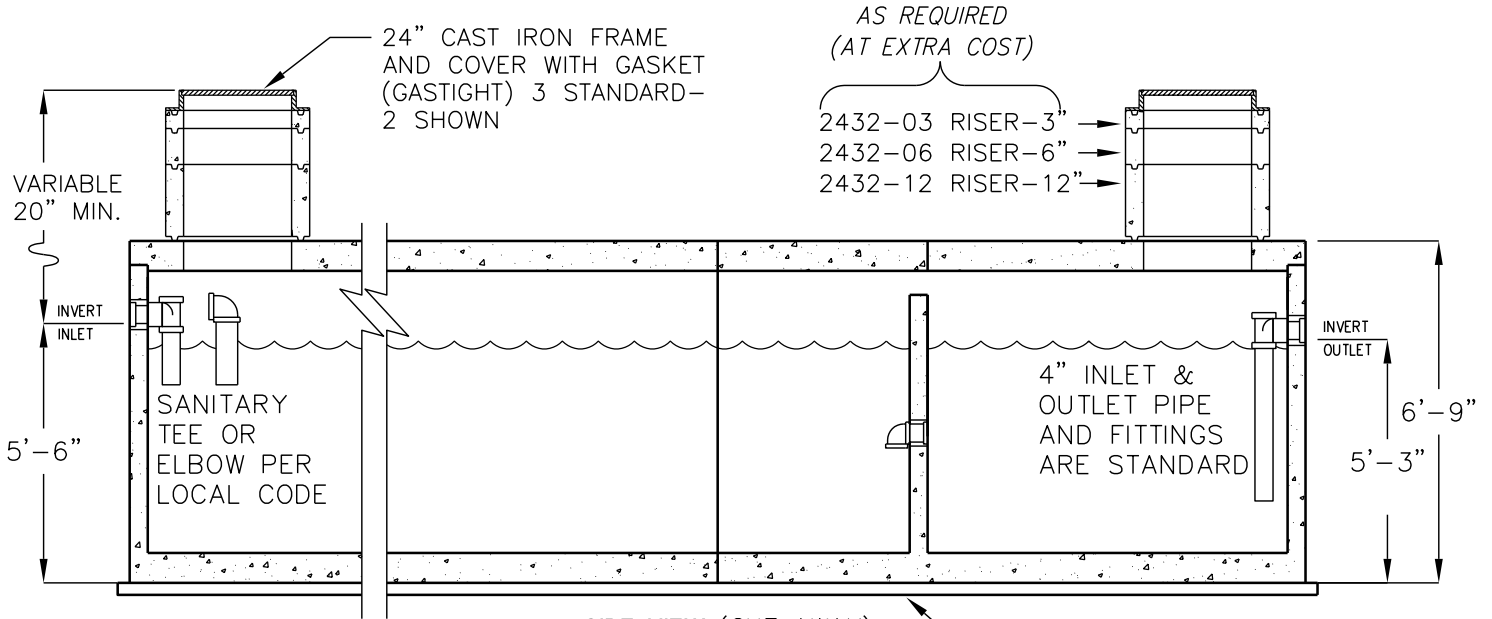

**SIDE VIEW (CUT AWAY)**

\*2x6 REDWOOD GRADE BOARDS  
(SUPPLIED BY OTHERS)

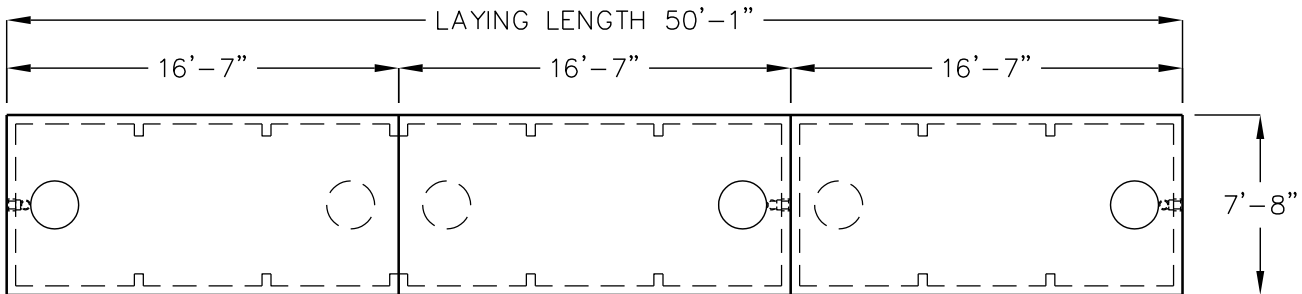

**TOP VIEW  
(COVERS  
REMOVED)**

○ = RECOMMENDED  
RISER/CAST IRON  
COVER LOCATIONS

○ = OPTIONAL  
RISER/CAST IRON  
COVER LOCATIONS

**ASSEMBLY SEQUENCE  
SIDE VIEW**

	1 TOP	2 TOP	3 TOP	
INLET	1 BASE	2 BASE	3 BASE	OUTLET

FOR INSTALLATION INSTRUCTIONS,  
DESIGN AND PRODUCT INFORMATION,  
CONTACT JENSEN PRECAST.

LIQUID CAPACITY: 12,000 GALLONS.  
BOX DESIGN LOAD: H-20 TRAFFIC FROM  
1' TO 5' OF SOIL COVER.