

# 48" I.D. TO 24" I.D. MANHOLE COMPONENT STACK

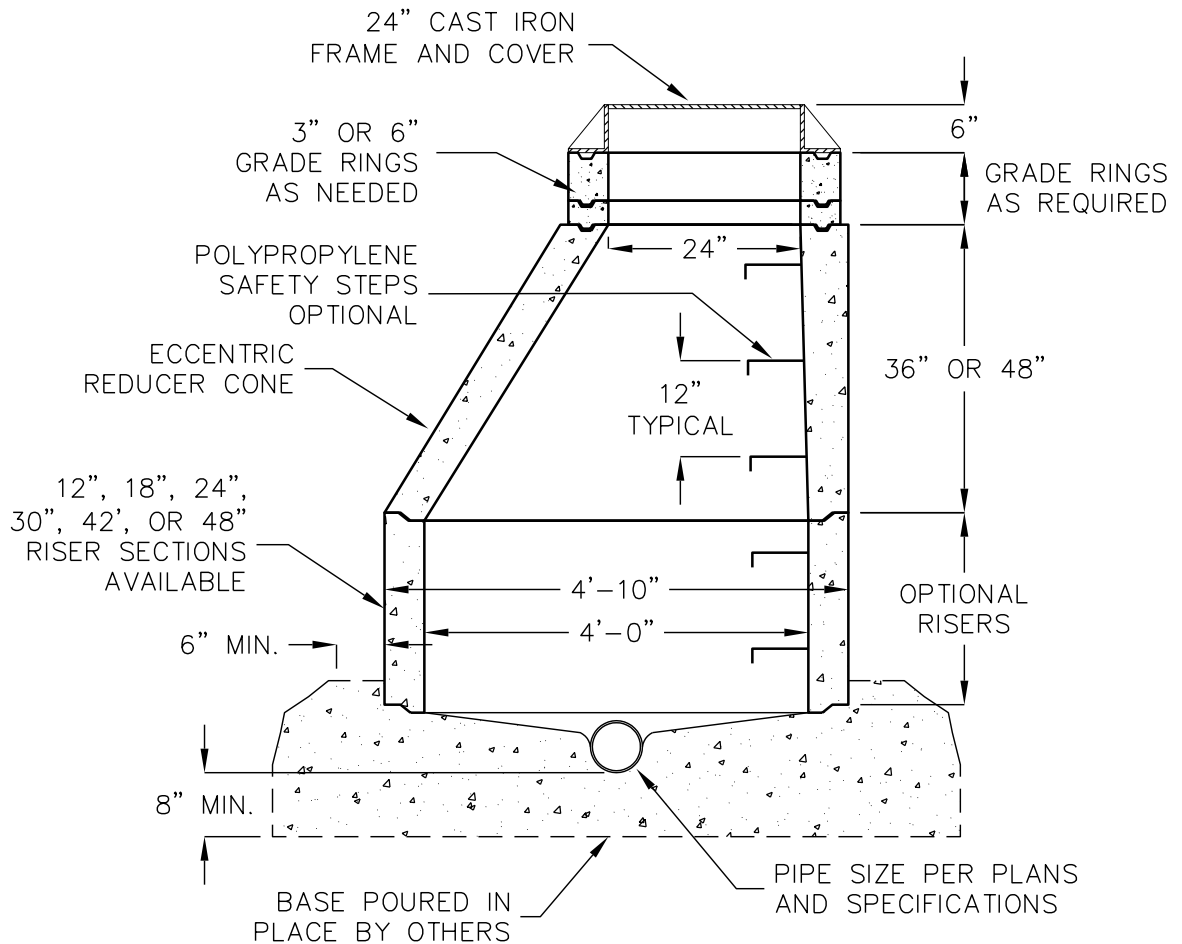

FOR COMPLETE DESIGN  
AND PRODUCT INFORMATION  
CONTACT JENSEN PRECAST.

MANHOLE COMPONENTS CONFORM TO  
CURRENT SPECIFICATIONS, ASTM  
C-478 AND AASHTO M199.