

1500 GALLON RESIDENTIAL SEPTIC TANK MODEL JS1500

NON-TRAFFIC ACCEPTED BY **UPC®**

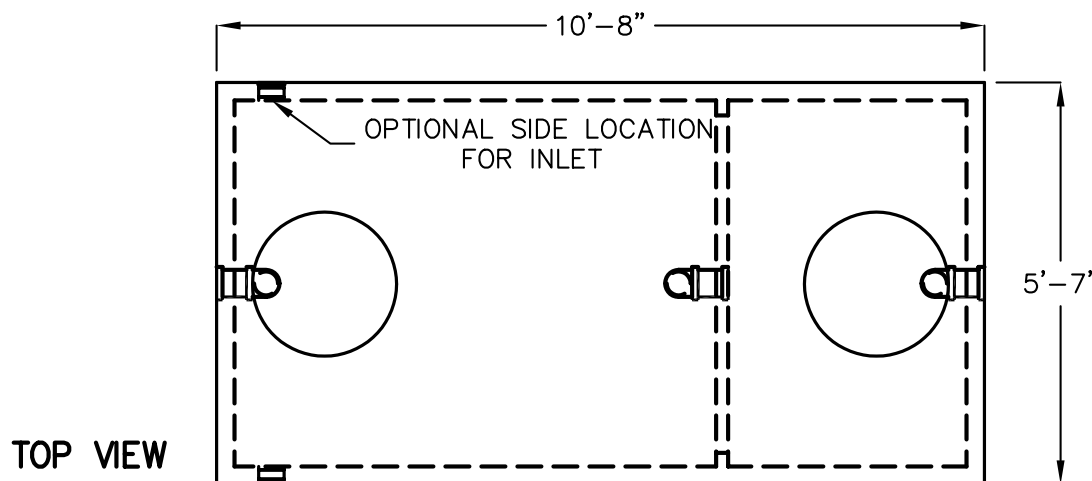
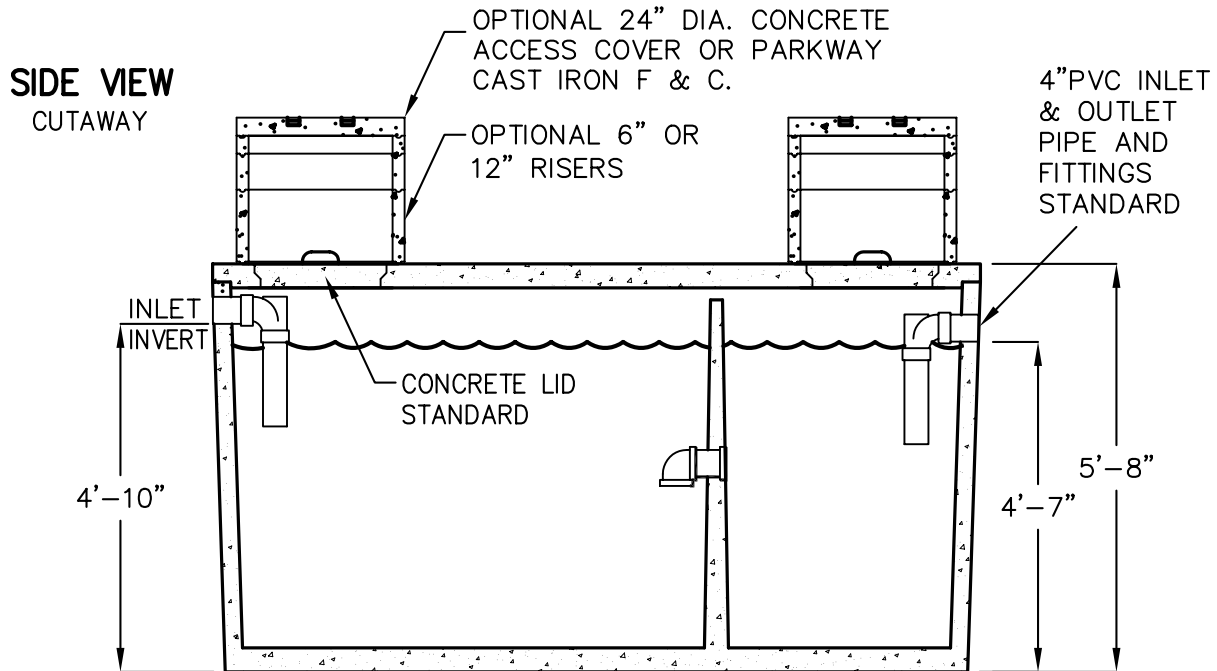

- LIQUID CAPACITY: 1500 GALLONS
TANK DESIGNED FOR NON-TRAFFIC USE WITH A MAXIMUM LOAD OF 500 PSF AND DRY SOIL CONDITIONS (WATER TABLE BELOW TANK). EARTH COVER OVER TANK NOT TO EXCEED 3'.
- THE PRECAST CONCRETE TANK SHALL BE PLACED ON LEVEL, UNDISTURBED SOIL OR APPROVED COMPACTED FILL.
- EFFLUENT FILTERS ARE AVAILABLE UPON REQUEST.
- FOR COMPLETE DESIGN AND PRODUCT INFORMATION CONTACT JENSEN PRECAST.

MINIMUM EXCAVATION SIZE:
6'-7" X 11'-8" X DEPTH REQ'D.

THE DESIGN AND DETAIL OF THIS DRAWING ARE THE PROPERTY OF JENSEN PRECAST AND NOT TO BE USED EXCEPT IN CONNECTION WITH ITS OWN WORK. DESIGN AND INVENTION RIGHTS ARE RESERVED.

