

687 BLANK

36" DIA. ACCESS OPENING

6'-0" X 8'-0" X 7'-0" I.D.
(NOMINAL DIMENSIONS)

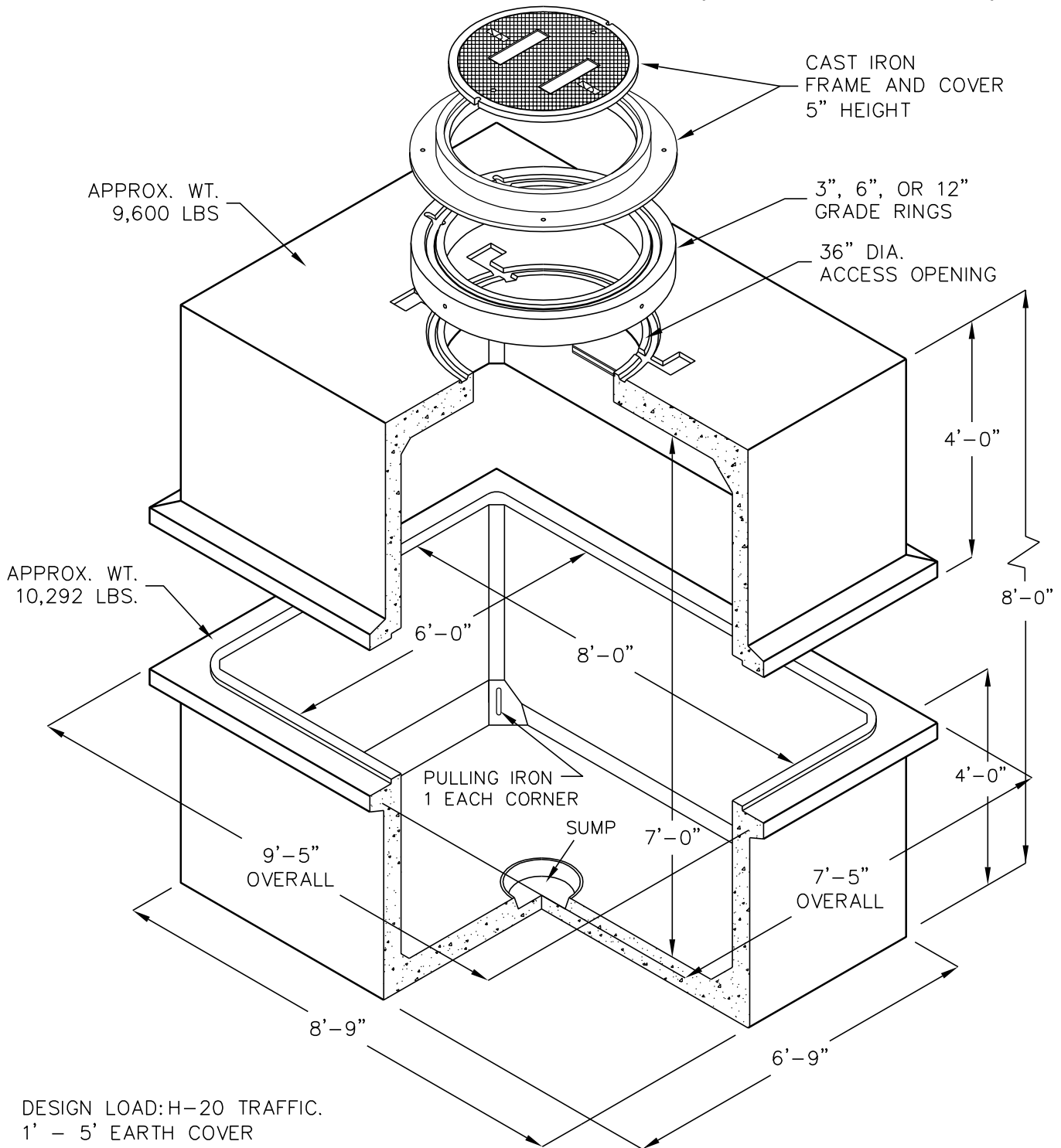

DESIGN LOAD: H-20 TRAFFIC.
1' - 5' EARTH COVER

FOR COMPLETE DESIGN AND PRODUCT INFORMATION
CONTACT JENSEN PRECAST.