

# 24"x36" DROP INLET

WITH OPTIONAL FRAME  
CAST IN EXTENSION

UP TO 6'-0" INSIDE DEPTH

DROP INLET			
MODEL NO.	A	B	* WEIGHT
DI243636	36"	42"	3028 LBS.
DI243648	48"	54"	3889 LBS.
DI243660	60"	66"	5611 LBS.
DI243672	72"	78"	6472 LBS.

\*BOX ONLY

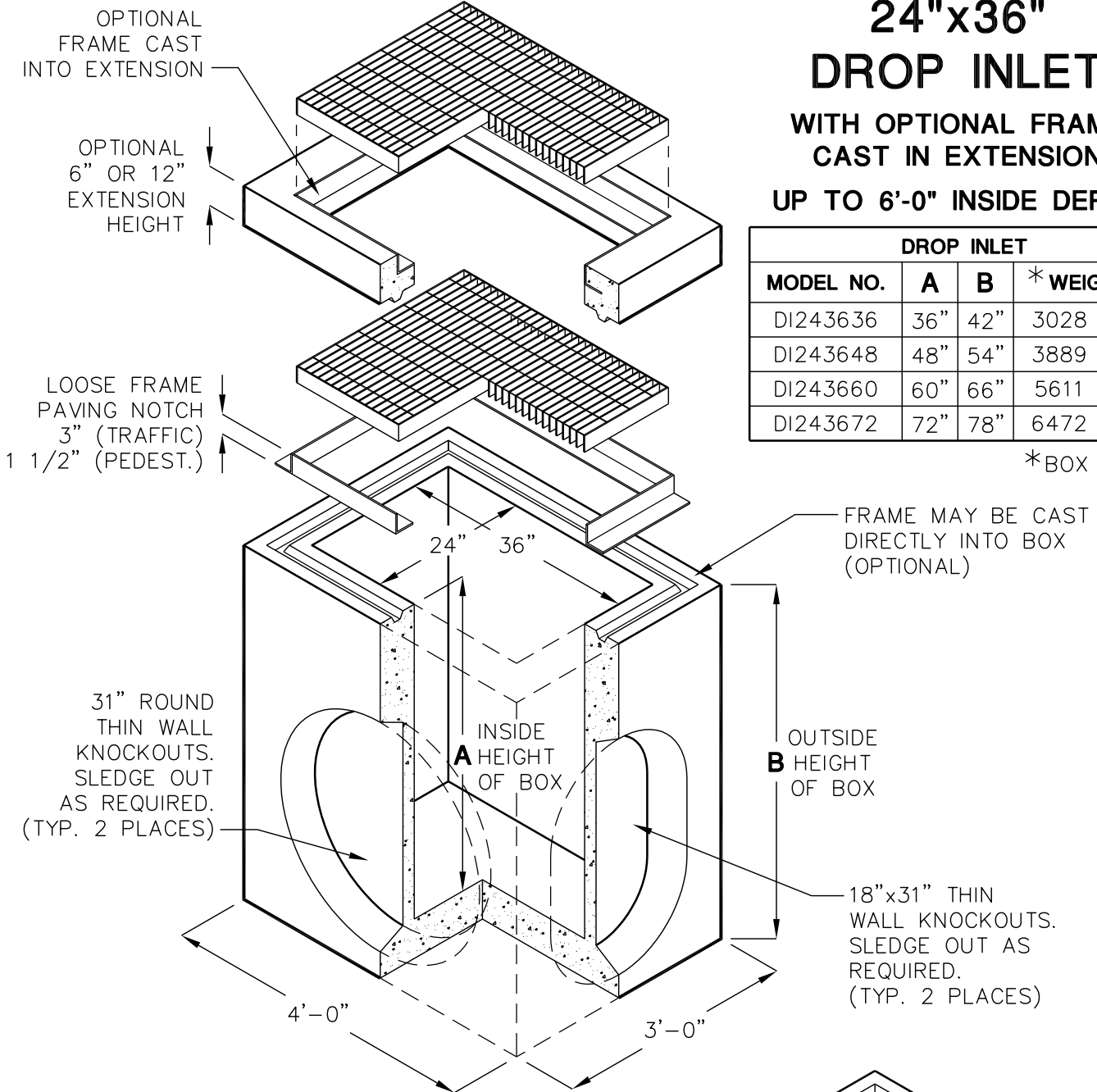

EXTENSION		
MODEL NO.	C	WEIGHT
RS243606	6"	450 LBS.
RS243612	12"	900 LBS.

FRAME AND GRATE  
ASSEMBLY AVAILABLE  
IN TRAFFIC OR  
PEDESTRIAN MODELS

BOX DESIGN LOAD:  
H-20 TRAFFIC

FOR COMPLETE DESIGN  
AND PRODUCT INFORMATION,  
CONTACT JENSEN PRECAST.

