

# 1500 GALLON COMMERCIAL SEPTIC TANK

MODEL JP1500EE-ST  
LISTED BY UPC®

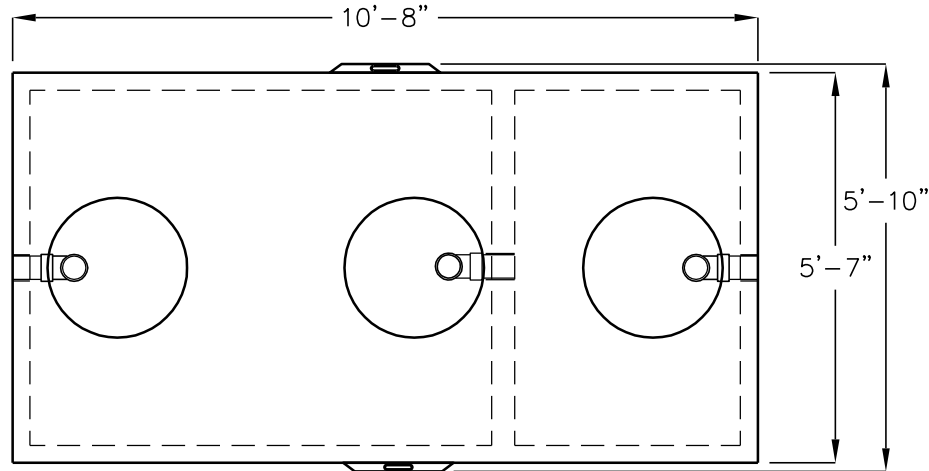

**TOP VIEW**  
(COVERS & RINGS REMOVED)

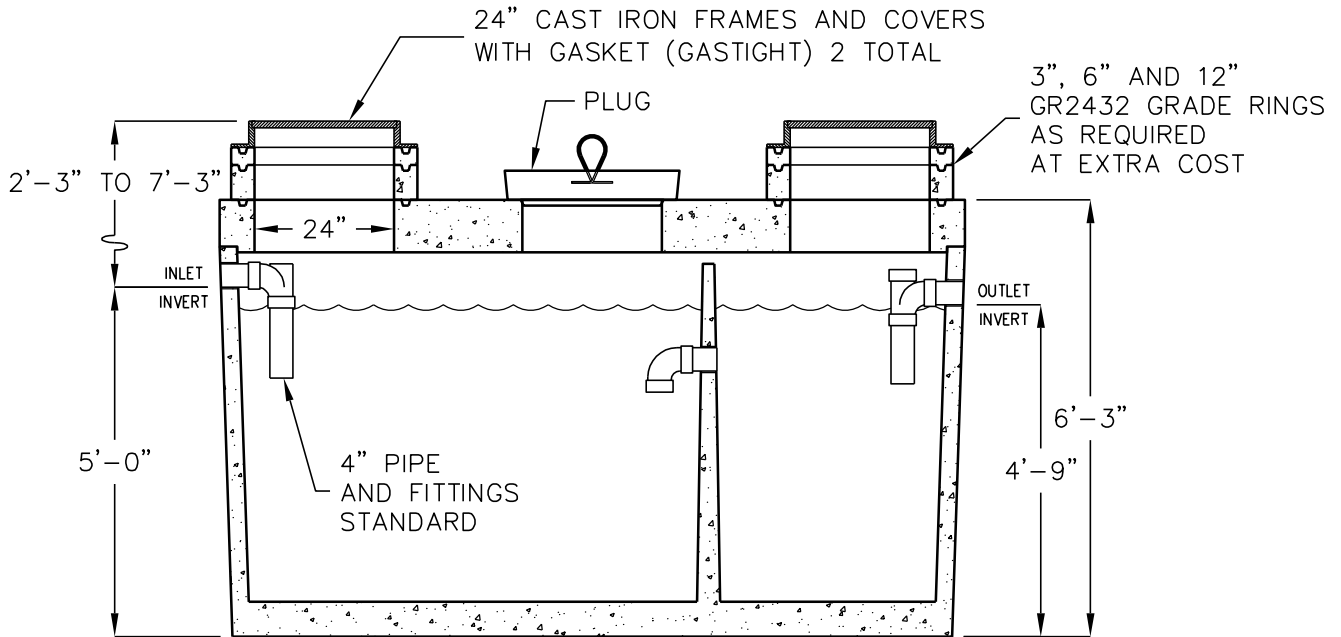

**SIDE SECTION VIEW**

OPERATING CAPACITY: 1,500 GALLONS.

DESIGN LOAD: H-20 TRAFFIC WITH DRY SOIL CONDITIONS  
(WATER LEVEL BELOW TANK) AND 1'-6' EARTH COVER.

SUITABLE SUB-BASE BEDDED WITH GRANULAR MATERIAL SHALL BE  
PREPARED TO HANDLE ANTICIPATED LOADS.

FOR COMPLETE DESIGN AND PRODUCT INFORMATION  
CONTACT JENSEN PRECAST.

MINIMUM EXCAVATION 6'-10" x 11'-8" x REQ'D DEPTH
--