

# 1000 GALLON GREASE INTERCEPTOR

MODEL JP1000ECE-G

LISTED BY UPC®

NAPA AND PLACER COUNTY,  
CITY OF ROSEVILLE

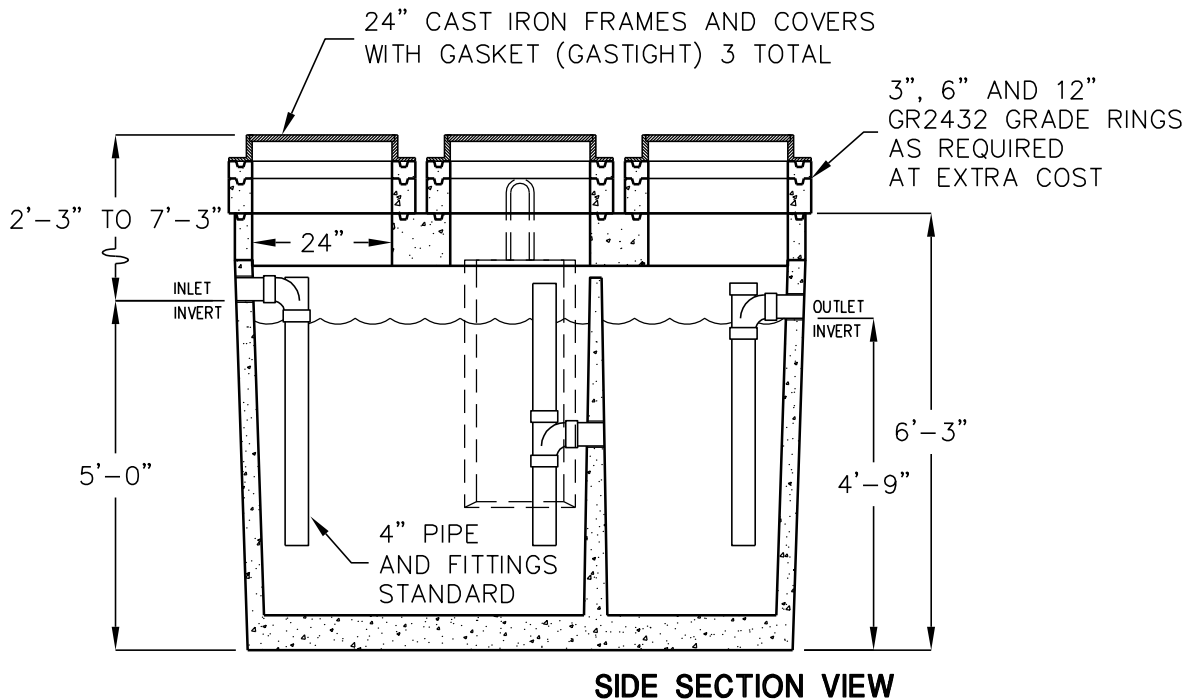
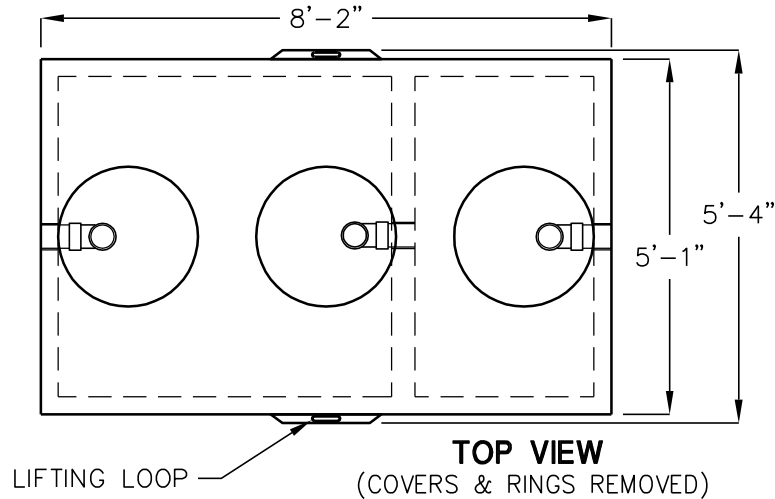

OPERATING CAPACITY: 1,000 GALLONS.

DESIGN LOAD: H-20 TRAFFIC WITH DRY SOIL CONDITIONS  
(WATER LEVEL BELOW TANK) AND 1'-6" EARTH COVER.

SUITABLE SUB-BASE BEDDED WITH GRANULAR MATERIAL SHALL BE  
PREPARED TO HANDLE ANTICIPATED LOADS.

FOR COMPLETE DESIGN AND PRODUCT INFORMATION  
CONTACT JENSEN PRECAST.

MINIMUM EXCAVATION  
6'-4" x 9'-2"  
x REQ'D DEPTH

7/2/07  
JP1000G\_ECE\_N&P\_A.dwg  
© 2007 Jensen Precast

Jensen Precast reserves the right to make changes to product design  
and/or dimensions without notice. Please contact Jensen Precast  
whenever necessary for confirmation or advice on product design.

**JENSEN**  
PRECAST