

# 96" I.D. PUMP/LIFT STATION

## LAYOUT FOR SIMPLEX OR DUPLEX SYSTEM

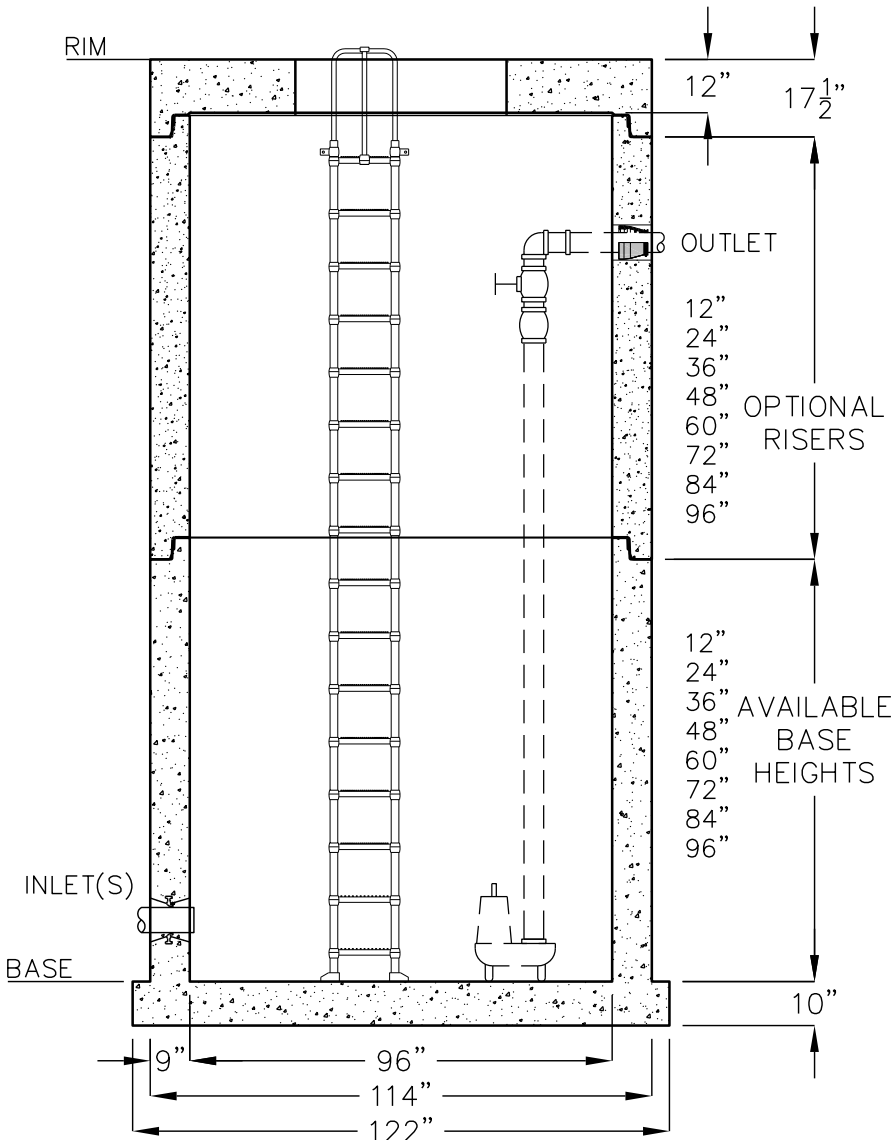

Complete the charts below to provide information about your pump station. Return this sheet to your Jensen Precast sales representative for assistance.

### PUMP STATION OPTIONS

#### HATCH

HATCH CLEAR OPENING \_\_\_\_\_"

#### HATCH MATERIAL:

- ALUMINUM
- GALVANIZED STEEL

#### DESIGN LOAD:

- PEDESTRIAN
- INCIDENTAL TRAFFIC
- FULL TRAFFIC

#### HATCH STYLE:

- WATER RESISTANT
- WATER TIGHT

#### PUMP/LIFT STATION

##### PIPE CONNECTOR(S):

- FLEXIBLE RESILIENT WATERTIGHT CONNECTOR
- OTHER

##### LADDER/STEPS:

- LADDER
- MANHOLE STEPS
- OTHER \_\_\_\_\_
- NONE

##### LINER:

- YES
- NO

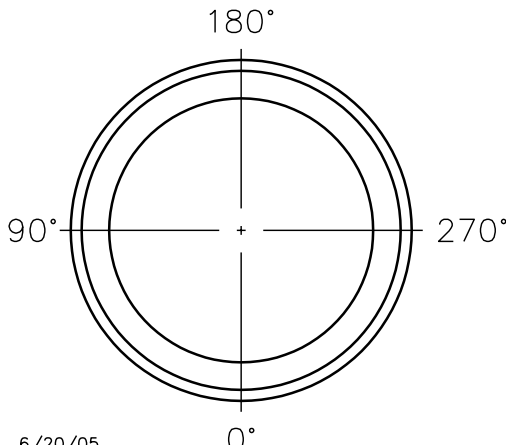

### PIPE PENETRATIONS, OPENING SIZES AND LOCATIONS

	ANGLE	PIPE SIZE	PIPE TYPE	ELEVATION
INLET 1				
INLET 2				
OUTLET				
VENT				
ELECTRICAL				
OTHER				