

# 48" I.D. PUMP/LIFT STATION

VARIOUS ACCESS OPENINGS AVAILABLE. OPTIONS INCLUDE: LOAD RATING\*, MATERIAL, FINISH, TYPE OF FRAME.

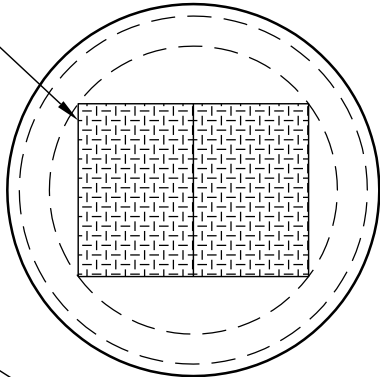

CONCRETE MANHOLE COMPONENTS CONFORM TO ASTM C-478 AND AASHTO M199. FLAT TOPS AND BASE SLABS ARE DESIGNED FOR AASHTO HS-20 WHEEL LOADING.

\*TRAFFIC RATED HATCHES – SUITABLE FOR USE IN OFF-STREET LOCATIONS WHERE NOT SUBJECTED TO HIGH DENSITY TRAFFIC.

O.S.H.A. APPROVED POLYPROPYLENE LADDER WITH SAFETY PULL-UP HANDRAIL. (OTHER STYLES AND FEATURES AVAILABLE)

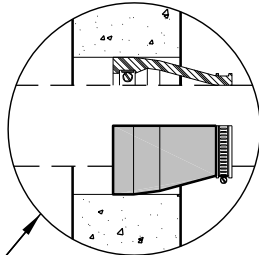

WATERTIGHT RESILIENT PIPE TO MANHOLE CONNECTOR. CONFORMS TO ASTM C-923. (BOOT STYLE SHOWN)

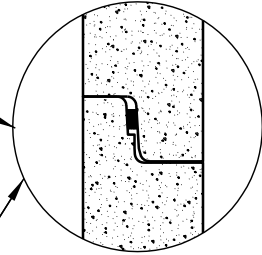
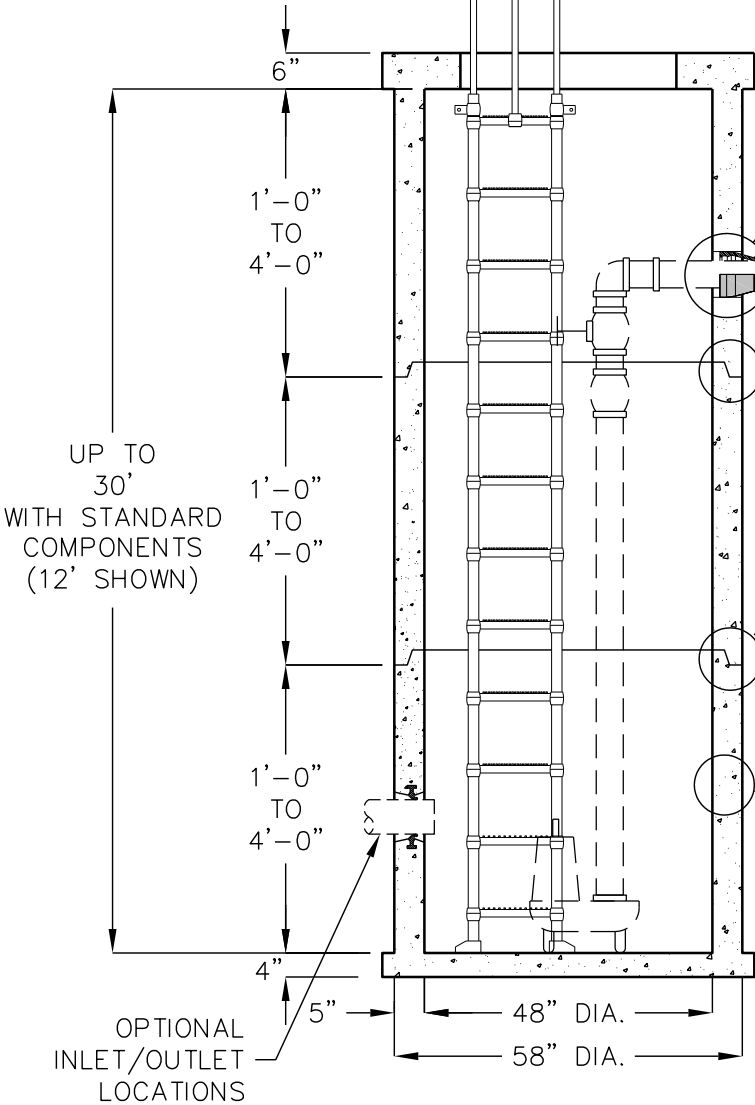

RE-ENGINEERED JOINT DESIGN FACILITATING SEALANT PLACEMENT TO ENSURE WATERTIGHT SEAM. SINGLE JOINT APPLICATION UP TO 8' DEPTH (12' SHOWN)

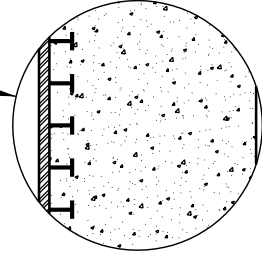

CORROSION RESISTANT LINER AVAILABLE.

CONTACT JENSEN PRECAST FOR ENGINEERING REQUIREMENTS TO ADDRESS BUOYANCY ISSUES.

**CALL JENSEN PRECAST FOR ASSISTANCE.**

