

PTS65 MANHOLE

FRONTIER COMMUNICATIONS
4'-6" W. x 8'-6" LG. x 6'-6" H.
(INSIDE DIMENSIONS)

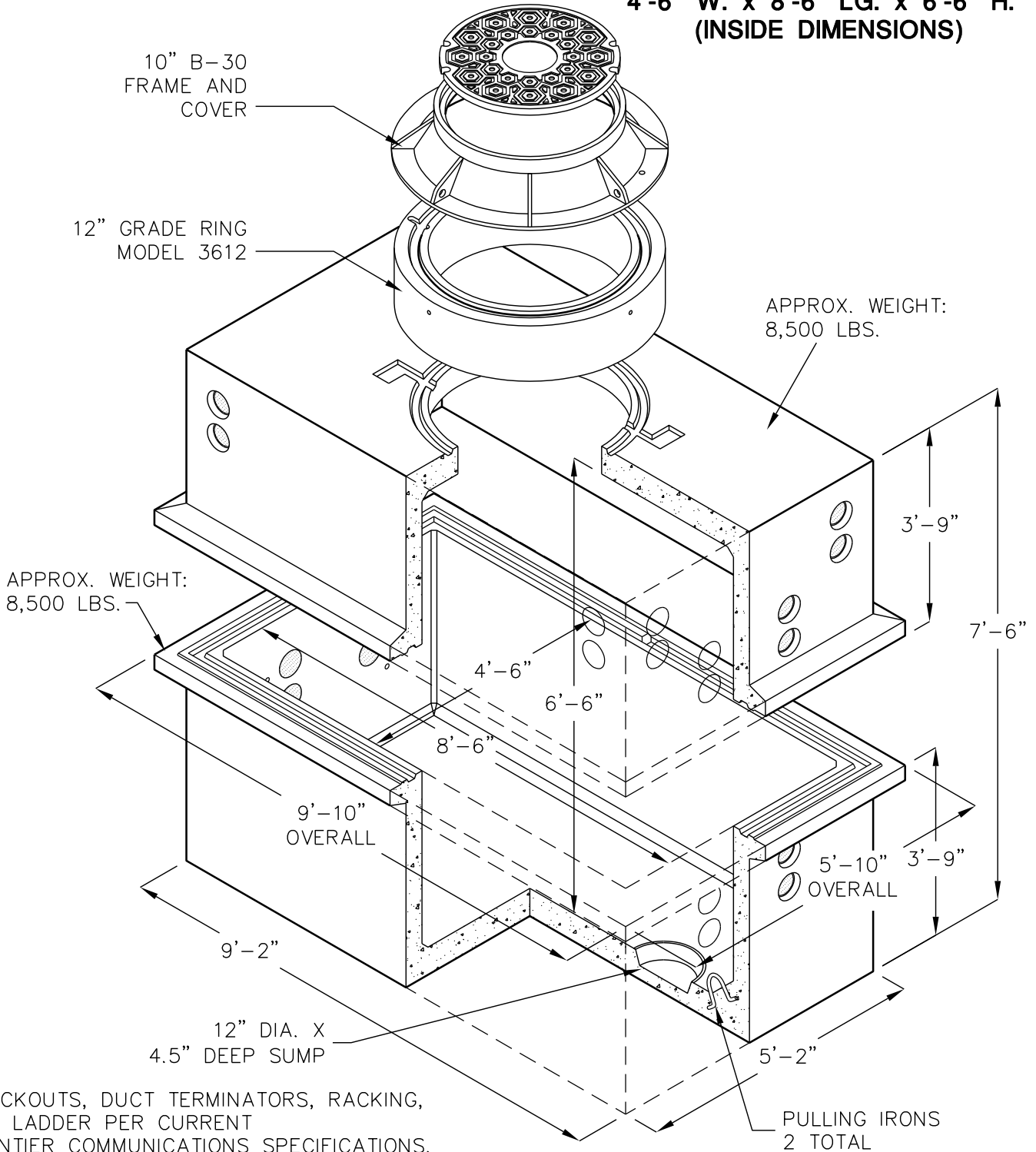

KNOCKOUTS, DUCT TERMINATORS, RACKING,
AND LADDER PER CURRENT
FRONTIER COMMUNICATIONS SPECIFICATIONS.

DESIGN LOAD: H-20 FULL TRAFFIC WITH 1' TO 5' EARTH COVER.

FOR COMPLETE DESIGN AND PRODUCT INFORMATION,
CONTACT JENSEN PRECAST.