

3660 PULLBOX

3'-0" x 5'-0" x 3'-0" I.D.
FRONTIER COMMUNICATIONS

*3660AT-TRF, 505 LBS. (H-20 TRAFFIC) OR
3660AT-PKY, 403 LBS. (NON TRAFFIC)
TORSION SPRING ASSISTED COVER

*NOTE:
THIS COVER MEETS H-20
WHEEL LOADING, HOWEVER,
IT IS NOT RECOMMENDED
FOR IN STREET USE. BEST FOR
USE IN OFF STREET LOCATIONS
OR OCCASIONAL TRAFFIC.

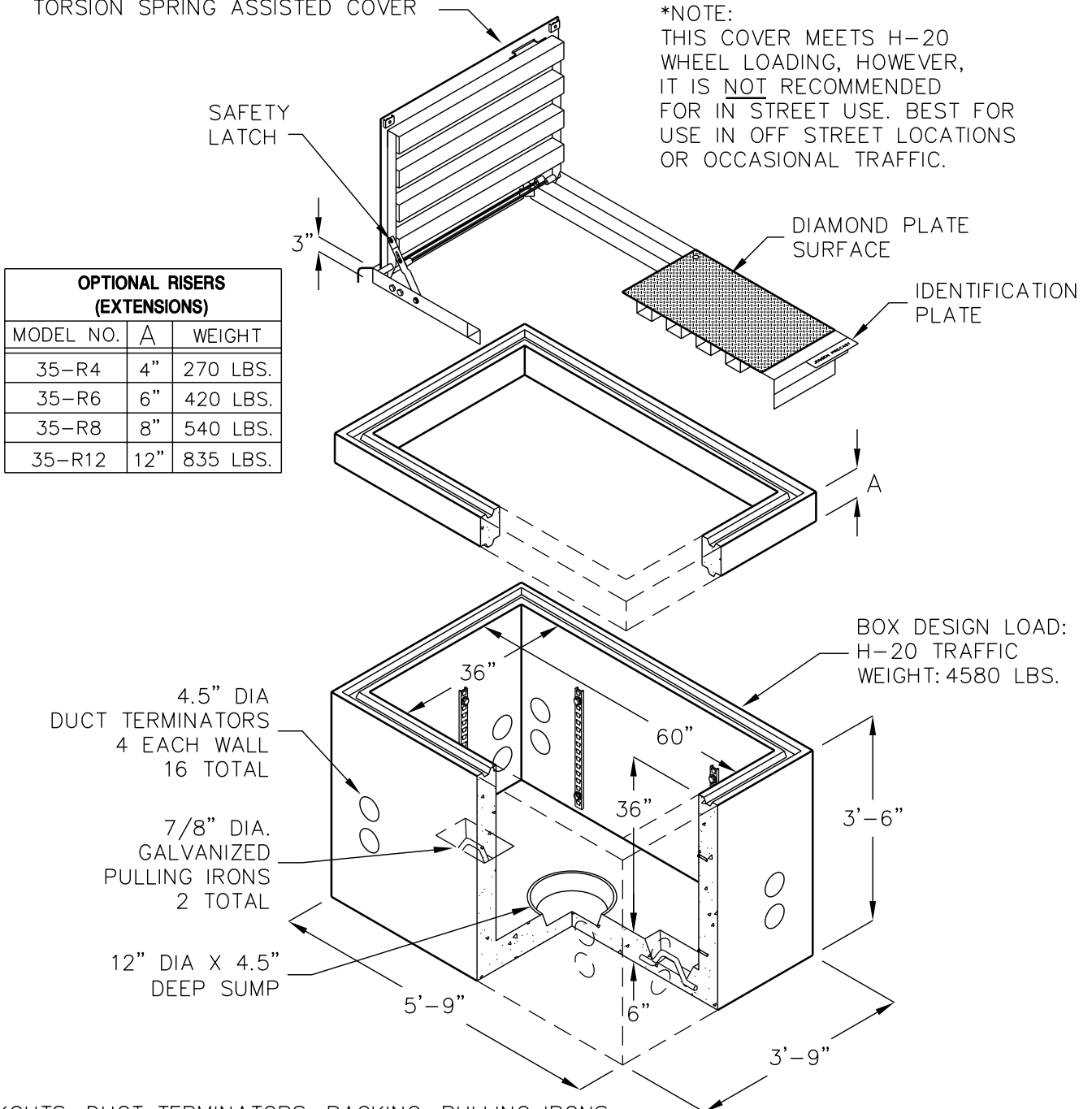

KNOCKOUTS, DUCT TERMINATORS, RACKING, PULLING IRONS,
INSERTS, ETC. PER CURRENT FRONTIER COMMUNICATIONS SPECIFICATIONS.

FOR COMPLETE DESIGN AND PRODUCT INFORMATION,
CONTACT JENSEN PRECAST.