

COMMERCIAL TANK EXCAVATION AND SITE PREPARATION

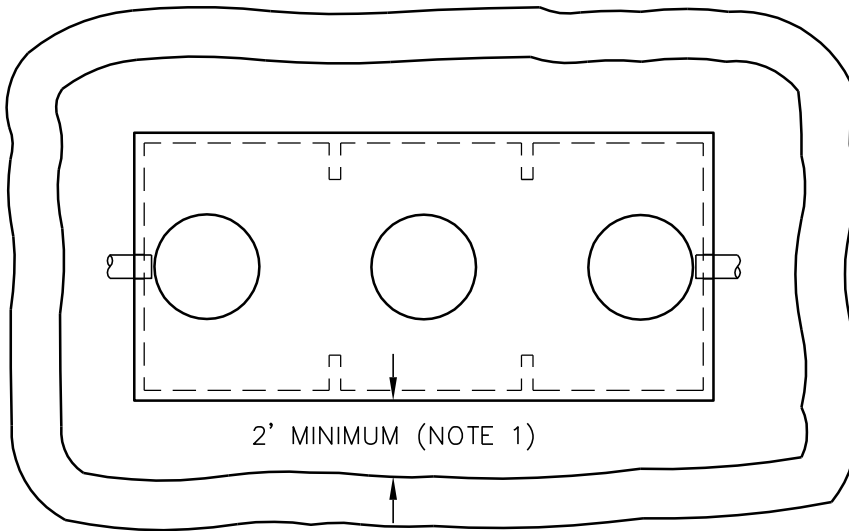

PLAN VIEW
(COVERS & RISERS REMOVED)

EXCAVATION
(NOTES 1 AND 2)

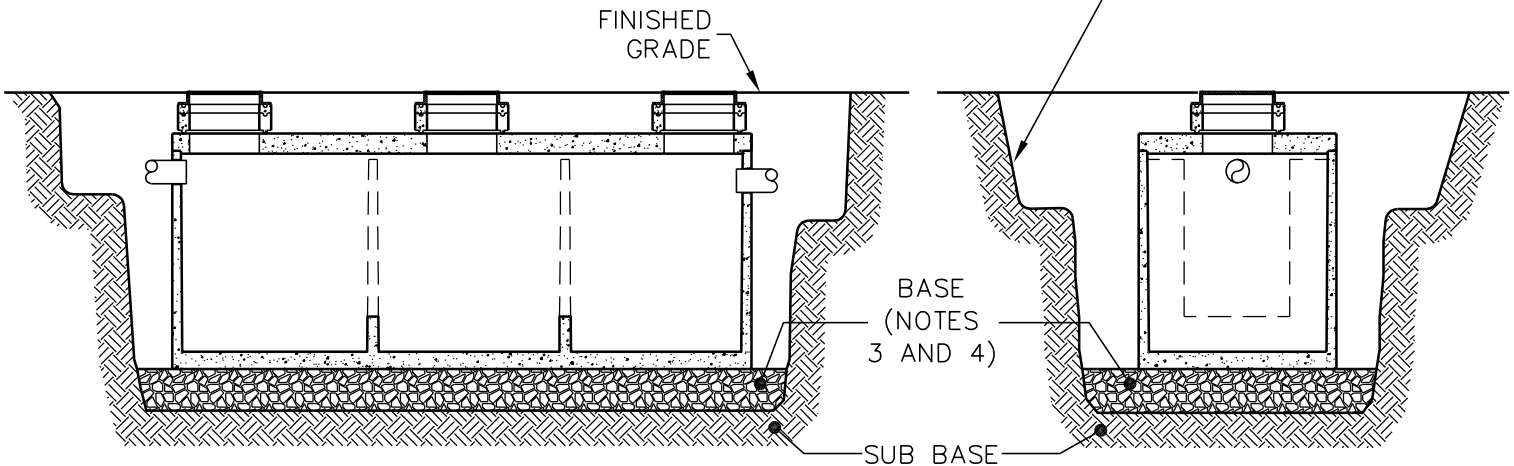

**SIDE ELEVATION
SECTION**

**END ELEVATION
SECTION**

NOTES:

1. AREA MUST BE PREPARED AND CLEARED TO 2 FEET MINIMUM SURROUNDING ENTIRE TANK.
2. THE EXCAVATION'S SLOPE, BENCHING OR SHORING SHALL COMPLY WITH THE REQUIREMENTS OF OSHA 29 CFR 1926 SUBPART P. JENSEN PRECAST WILL NOT VIOLATE THIS OSHA STANDARD IN THE COURSE OF SETTING AND SEALING THE TANK.
3. BASE MUST BE LEVEL AND EVEN IN ALL DIRECTIONS.
4. THE EXCAVATION SHALL BE BEDDED WITH SUITABLE GRANULAR MATERIAL AND SHALL BE COMPACTED TO 90% OF IT'S MAXIMUM DRY DENSITY OR TO THE REQUIREMENTS OF THE PROJECT GEOTECHNICAL ENGINEER.

DRAWING NOT TO SCALE

Jensen Precast reserves the right to make changes to product design and/or dimensions without notice. Please contact Jensen Precast whenever necessary for confirmation or advice on product design.