

5000 GALLON GREASE INTERCEPTOR-HAWAII

MODEL HJ5000G

TRAFFIC RATED ACCEPTED BY UPC®

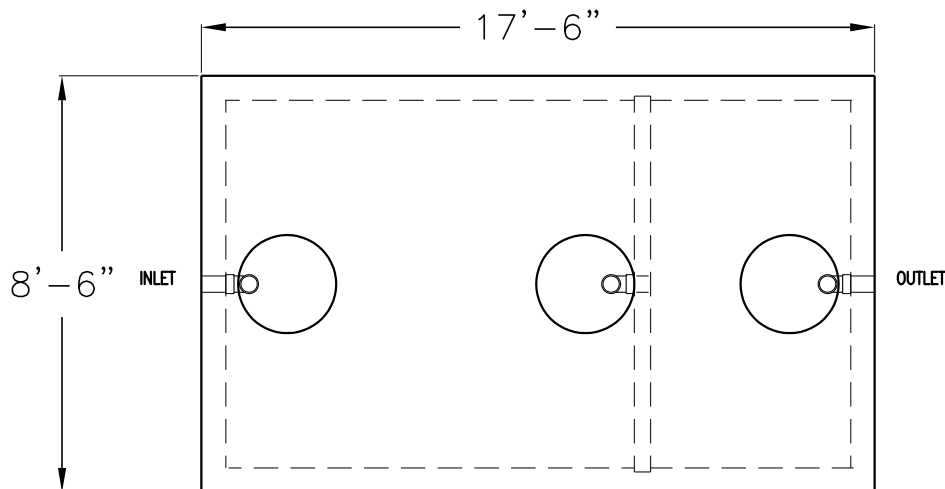

PLAN VIEW

WEIGHTS IN LBS.

| | |
|------------|--------|
| TOP SLAB | 14,000 |
| BODY | 36,700 |
| TOTAL TANK | 50,700 |

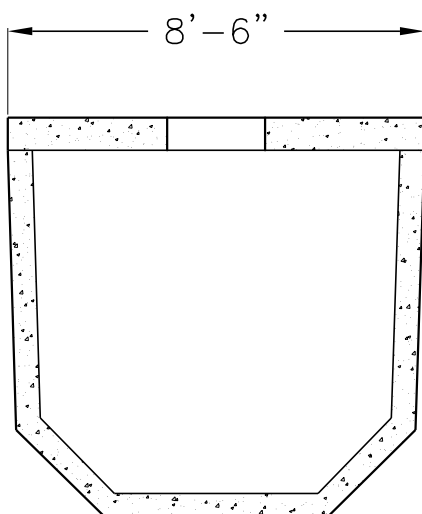

CROSS SECTION

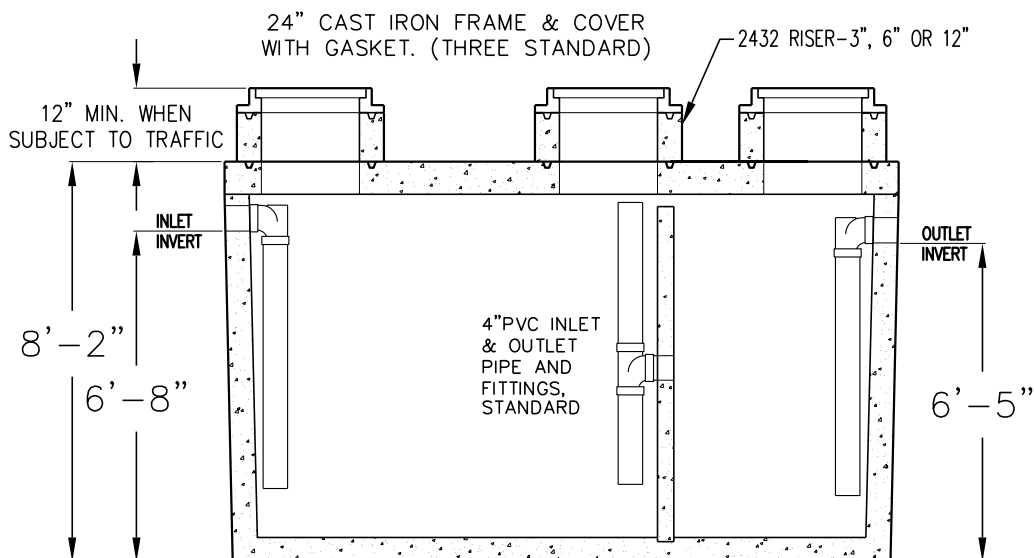

LONGITUDINAL SECTION

- LIQUID CAPACITY: 5000 GALLONS.
- TANK DESIGNED FOR H-20 TRAFFIC WHEEL LOAD WITH 1' TO 6' MAX. EARTH COVER AND WATER TABLE AT ONE FOOT BELOW GRADE.
- SUITABLE NATIVE SOIL OR GRANULAR SUB-BASE SHALL BE COMPACTED AND LEVELED TO HANDLE ANTICIPATED LOADS. SEE INSTALLATION PROCEDURES SHEET FOR ADDITIONAL INFO.
- EXTERIOR AND INTERIOR CONCRETE SURFACES TO BE COATED WITH AN APPROVED BITUMINOUS MATERIAL.
- FOR COMPLETE DESIGN AND PRODUCT INFORMATION CONTACT JENSEN PRECAST.

THE DESIGN AND DETAIL OF THIS DRAWING ARE THE PROPERTY OF JENSEN PRECAST AND NOT TO BE USED EXCEPT IN CONNECTION WITH ITS OWN WORK. DESIGN AND INVENTION RIGHTS ARE RESERVED.

MINIMUM EXCAVATION SIZE:
9'-6" X 18'-6" X DEPTH REQ'D.