

500 GALLON GREASE INTERCEPTOR

MODEL HJ500G
LISTED BY UPC®

WEIGHTS IN LBS.

TOP SLAB	2,150
BODY	11,500
TOTAL TANK	13,650

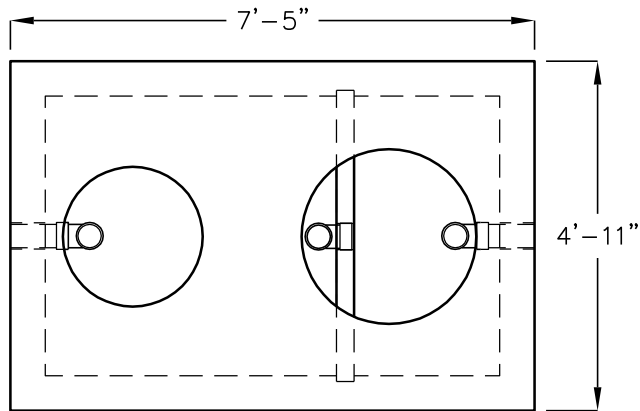

PLAN VIEW
(COVERS AND RINGS NOT SHOWN)

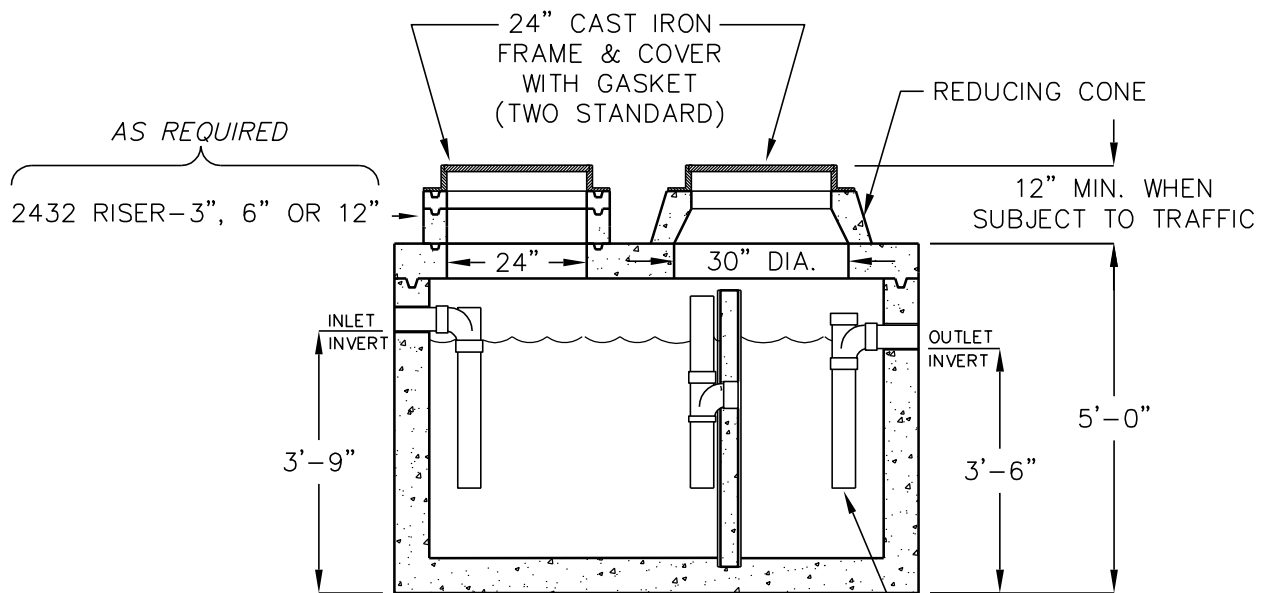

SIDE SECTION VIEW

LIQUID CAPACITY: 500 GALLONS.

DESIGN LOAD: H-20 TRAFFIC WITH DRY SOIL CONDITIONS (WATER LEVEL BELOW TANK) AND 1'-6" EARTH COVER.

SUITABLE SUB-BASE BEDDED WITH GRANULAR MATERIAL SHALL BE PREPARED TO HANDLE ANTICIPATED LOADS.

EXTERIOR AND INTERIOR CONCRETE SURFACES TO BE COATED WITH AN APPROVED BITUMINOUS MATERIAL.

FOR COMPLETE DESIGN AND PRODUCT INFORMATION CONTACT JENSEN PRECAST.

MINIMUM EXCAVATION
6'-0" x 8'-6"
x REQ'D DEPTH