

3660 INTERCEPT PULLBOX

3'-0" x 5'-0" x 3'-0" I.D.
FRONTIER COMMUNICATIONS

*3660AT-TRF, 505 LBS. (H-20 TRAFFIC) OR
3660AT-PKY, 403 LBS. (NON TRAFFIC)
TORSION SPRING ASSISTED COVER

*NOTE:
THIS COVER MEETS H-20
WHEEL LOADING, HOWEVER,
IT IS NOT RECOMMENDED
FOR IN STREET USE. BEST FOR
USE IN OFF STREET LOCATIONS
OR OCCASIONAL TRAFFIC.

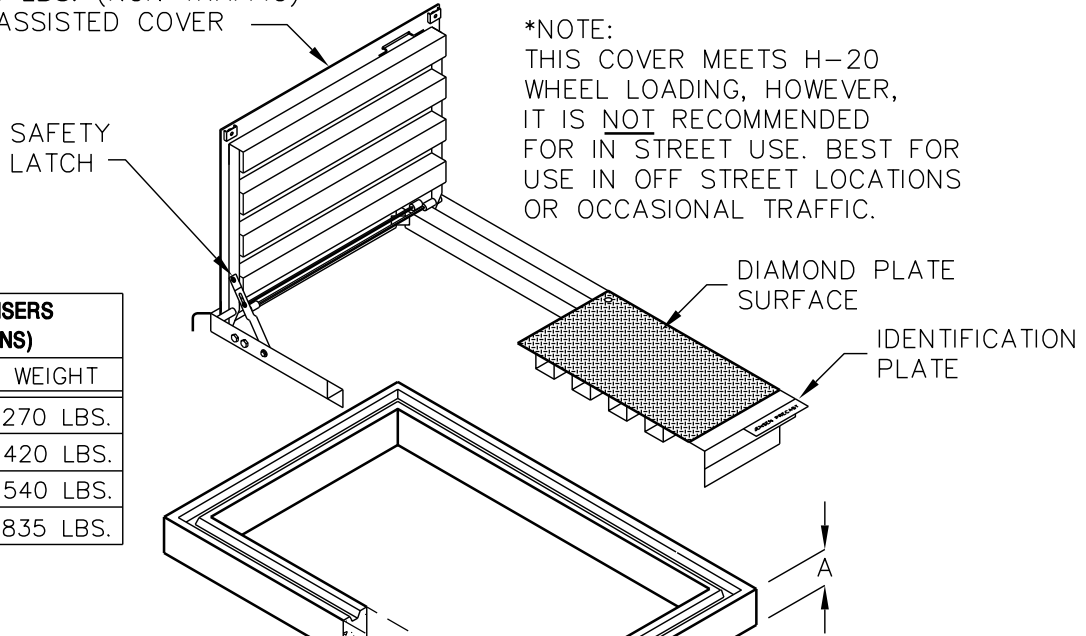

OPTIONAL RISERS (EXTENSIONS)		
MODEL NO.	A	WEIGHT
35-R4	4"	270 LBS.
35-R6	6"	420 LBS.
35-R8	8"	540 LBS.
35-R12	12"	835 LBS.

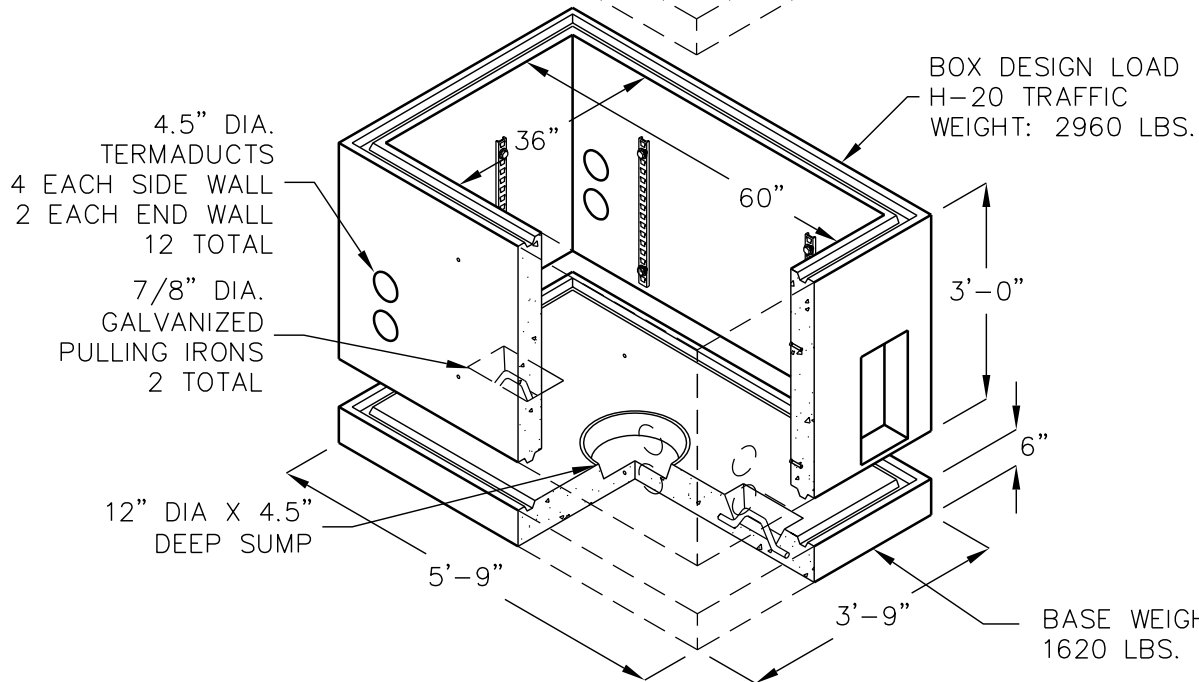

KNOCKOUTS, DUCT TERMINATORS, RACKING, PULLING IRONS, INSERTS,
ETC. PER CURRENT FRONTIER COMMUNICATIONS SPECIFICATIONS.

FOR COMPLETE DESIGN AND PRODUCT INFORMATION, CONTACT JENSEN
PRECAST.