

# 3'-0" x 5'-0" VERIZON TRAFFIC DUCTED PULL BOX x 36" DEEP

**NOTES:**

- PULL BOX DESIGNED IN ACCORDANCE WITH AASHTO H-20-44 TRAFFIC BRIDGE LOADING USING 5,300 PSI COMPRESSIVE STRENGTH CONCRETE AND 60,000 PSI YIELD STRENGTH ASTM A-706 STEEL REINFORCEMENT.
- STEEL COVER DESIGNED FOR TRAFFIC H-20 LOADING
- PULL BOX TO BE PLACED ON A MIN. 6" BASE OF CRUSHER RUN FOR EASE OF INSTALLATION AND EVEN LOAD DISTRIBUTION.

1. PB3660D-B30-05, 30" BOTTOM SECTION, WT. 3,520 Lbs.
2. PB3660-TT, 6" TOP SECTION, W/ F & C CAST-IN W/ ONE COAT ALUMINUM FINISH, WT. 630 Lbs.
3. TWO PIECE SLIP RESISTANT TRAFFIC HINGED COVER, W/(2) 1/2" S.S. BOLTS, RED PRIMER, ALUMINUM FINISH, MARKED "STE"
4. 6" DIA. SUMP" x 3 1/2" DEEP, BOTTOM SECTION (1)
5. 26" x 26 1/2" DUCTED K.O. x 12" DEEP, BOTTOM SECTION (2).
6. 8" x 16" K.O. x 3" DEEP, BOTTOM SECTION (4).
7. 1" DIA. BLIND GROUND ROD HOLE, BOTTOM SECTION (2).
8. 7/8" x 4 1/2" GALV. PULL IRON BOTTOM SECTION (2).
9. 1/2" P-36-T INSERT, LOCATE AS FOLLOWS: TOP SECTION (4).
10. 1/2" PLASTIC RACKING INSERTS, BOTTOM SECTION (20).

**RACKING PACKAGE:**

14 HOLE CABLE RACKS W/BOLTS = 4.

**ORDERING INFORMATION:**

K3660-DP36-1TSA FOR ASSEMBLY AS SHOWN.  
APPROVED PER VERIZON SPEC.  
TOTAL WEIGHT OF ASSEMBLY SHOWN IS 4,860 Lbs.

**GENERAL NOTES:**

1. Minimum soil bearing capacity is hereby assumed to be 2000 PSF unless otherwise documented by a geotechnical report that shall be provided to Jensen Precast by the end user. Jensen Precast shall not be held responsible for the soil bearing capacity.
2. Installation of Manholes, Vaults, Handholes, Meter Boxes etc. will be as per Jensen installation procedures.
3. Structural modification to the Jensen line of products is not permitted without prior written approval from Jensen Engineering Department.
4. Do not scale the drawings, verify all dimensions including rough openings, if any discrepancies are found, notify the Jensen Engineer immediately.
5. The Jensen Engineer will interpret the intent of the drawings in case of possible conflict or discrepancy.
6. Permissible Variations:  
Dimensional Tolerances – The length, width, height, or dia. measurements of the structure when measured on the inside surfaces shall not deviate from design dimensions by more than the following:  
Dimensions: Tolerance:  
0 to 5 Feet 1/4"  
5 to 10 Feet 3/8"  
10 to 20 Feet as agreed upon between the supplier and purchaser.  
Squariness Tolerance:  
The inside of the precast concrete component shall be square as determined by diagonal measurements. The difference between such measurements shall not exceed the following:  
Measured Length: Allowable Difference  
0 to 10 Feet 1/2"  
10 to 20 Feet 3/4"  
20 Feet and over as agreed upon between the supplier and purchaser.
- 7.

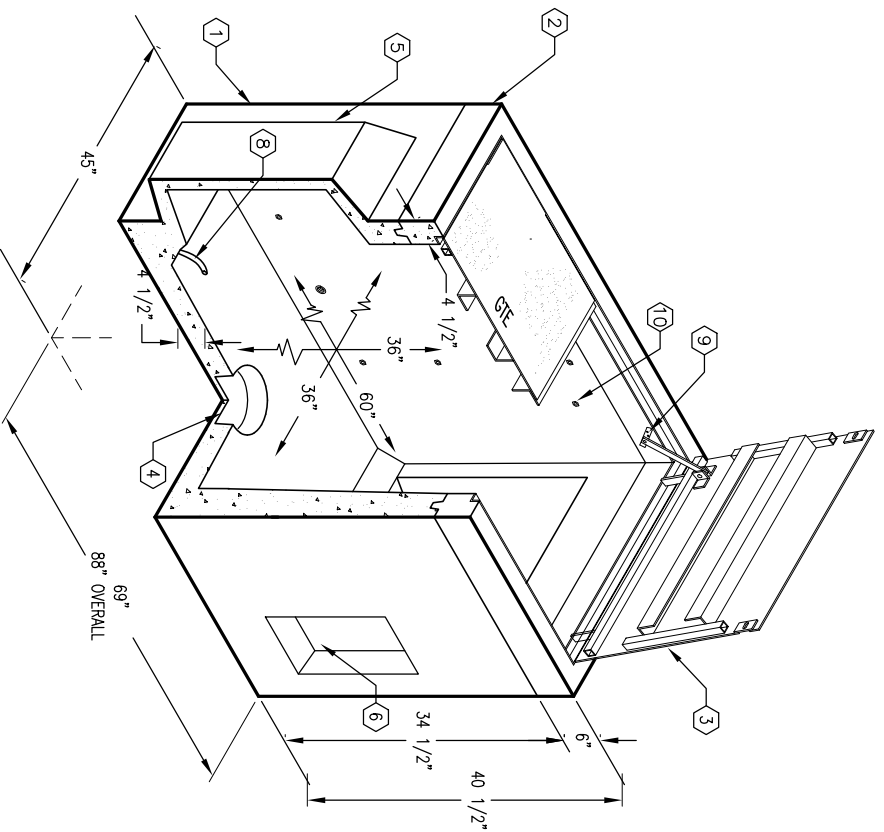

MINIMUM EXCAVATION SIZE:  
4'-9" x 8'-4" x DEPTH REQ'D.

**JENSEN PRECAST**  
K3660-DP36-13

AUTOCAD REL. 14

PER VERIZON SPEC. 03-01-02

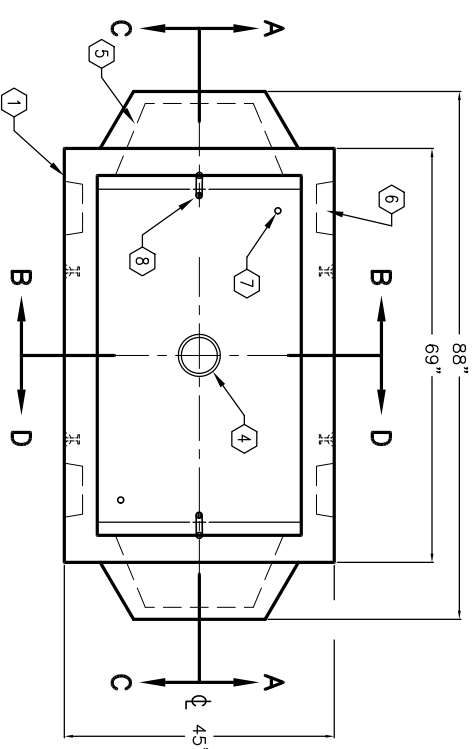

**PLAN VIEW**

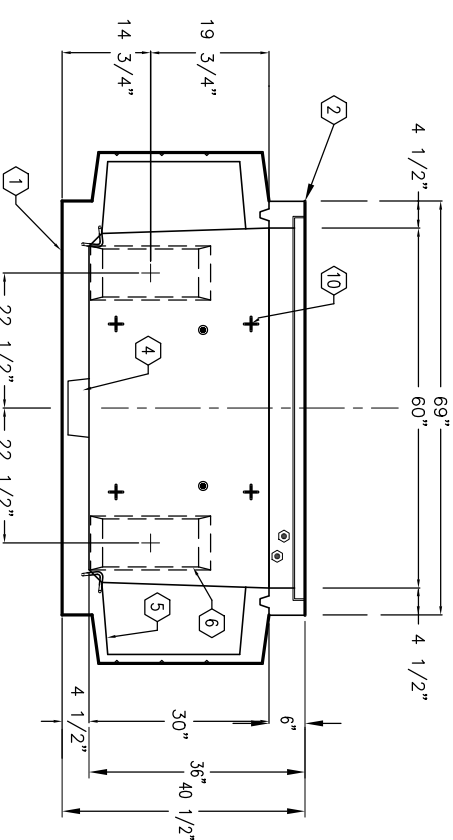

**SECTION C-C**

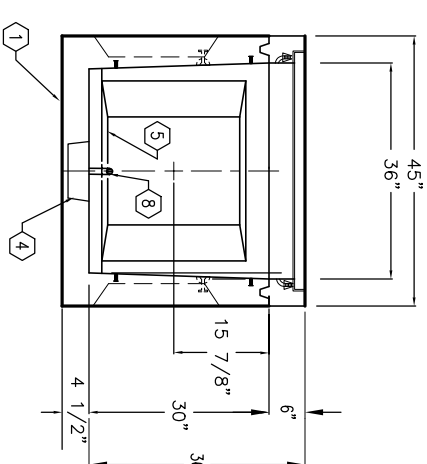

**SECTION D-D**

**JENSEN PRECAST**

#	DATE	DESCRIPTION	BY

**JENSEN PRECAST**  
K3660-DP36-13

PER VERIZON SPEC. 03-01-02