

# 3'-0" x 5'-0" VERIZON DUCTED INTERCEPT BOX x 48" DEEP

**NOTES:**

□ PULL IRON BOX DESIGNED IN ACCORDANCE WITH ASHTO H-20-44 TRAFFIC BRIDGE LOADING USING 5,500 PSI COMPRESSIVE STRENGTH CONCRETE AND 60,000 PSI YIELD STRENGTH ASTM A-706 STEEL REINFORCEMENT.

□ STEEL COVER DESIGNED FOR PARKWAY LOADING 300 psf. OR TRAFFIC H-20 LOADING.

■ PULL BOX TO BE PLACED ON A MIN. 6" BASE OF CRUSHER RUN FOR EASE OF INSTALLATION AND EVEN LOAD DISTRIBUTION.

**RACKING PACKAGE:**

18 HOLE CABLE RACKS W/BOLTS = 4.

**ORDERING INFORMATION:**

TOTAL WEIGHT OF ASSEMBLY IS 6,541#.

**PARKWAY ASSEMBLY WITH STEEL HINGED COVER K3660-DI48-13PSA**

**LIGHT TRAFFIC ASSEMBLY WITH STEEL HINGED COVER K3660-DI48-13ISA**

1. PB3660-B7, 7" BOTTOM SECTION, WT. 2,980#.
2. PB3660-I35-05, 35" INTERCEPT SECTION, WT. 2,852#.
3. PB3660-TP/TT, 6" TOP SECTION, W/ FRG CAST-IN.
4. TWO PIECE SLIP RESISTANT HINGED PARKWAY OR TRAFFIC COVER W/(2) 1/2" S.S. BOLTS, RED PRIMER, ALUMINUM PAINT FINISH. MARKED "VERIZON".
5. 6" DIA. X 7" DIA. SUMP X 2" DEEP. BOTTOM SLAB (1).
6. 18" x 24 1/4" KNOCKOUT X 4" DEEP. INTERMEDIATE SECTION (2).
7. 8" X 16" KNOCKOUT X 4" DEEP. INTERMEDIATE SECTION (4).
8. 1" DIA. BLIND GROUND ROD HOLE. BOTTOM SECTION (2).
9. 7/8" DIA. X 9" GALVANIZED PULL IRON. BOTTOM SECTION (2).
10. 1/2" 1-5000 PLASTIC RACKING INSERT. LOCATE AS FOLLOWS: INTERMEDIATE SECTION (16).
11. 1/2" P-36-1 O.B. INSERT. LOCATE AS FOLLOWS: TOP SECTION (8).

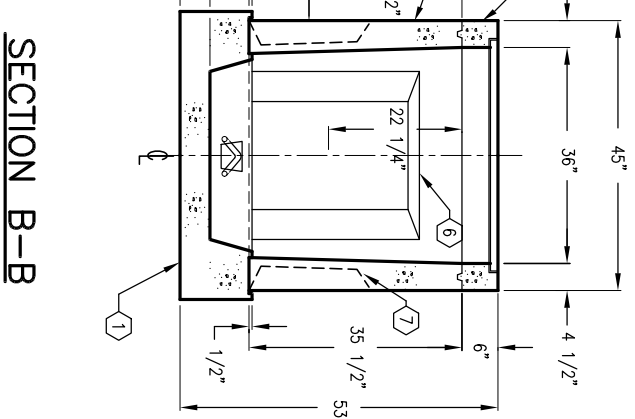
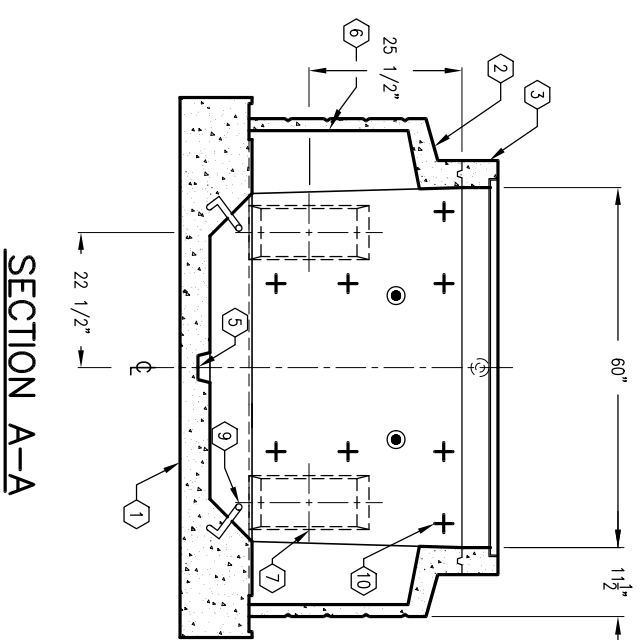
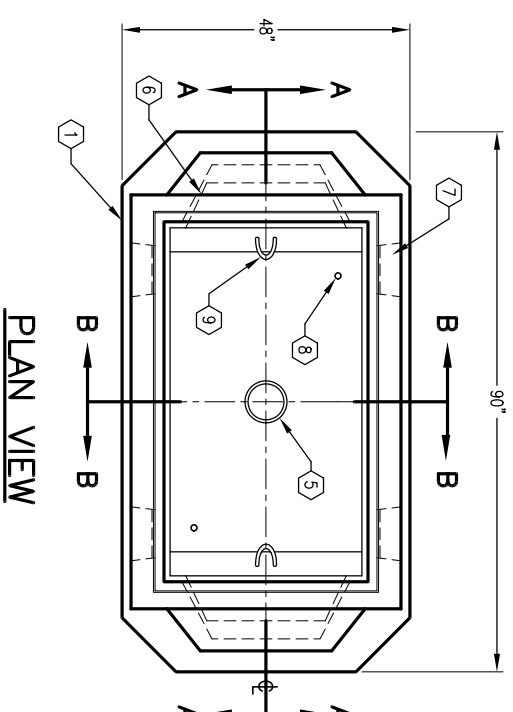
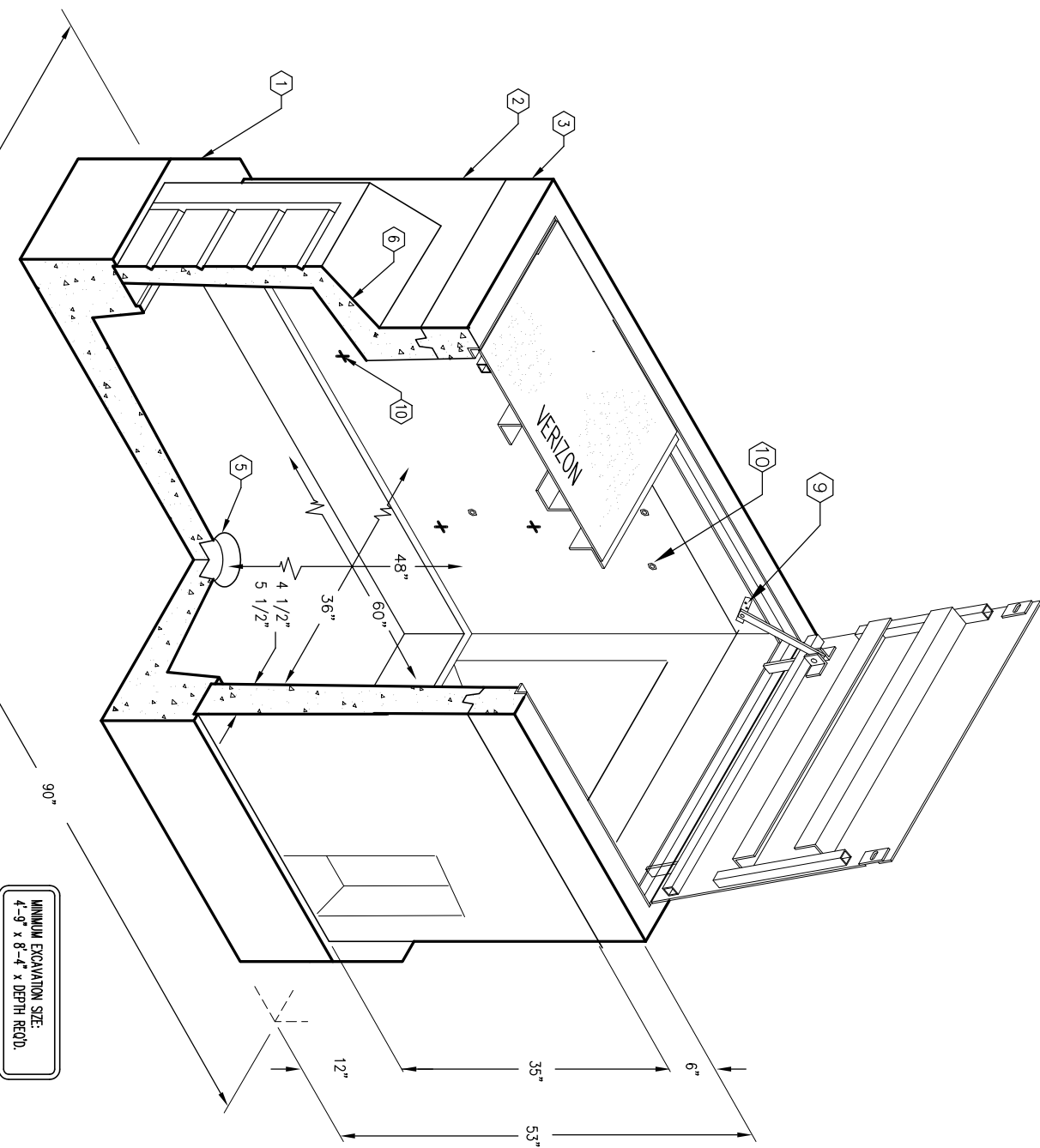

#	DATE	DESCRIPTION	BY