

# 466TA-I INTERCEPT PULLBOX

4'-0" x 6'-6" x 3'-0"  
(NOMINAL INSIDE DIMENSIONS)

\*4878AT-TRF TORSION  
SPRING ASSISTED COVER  
APPROX. WEIGHT:  
790 LBS.

\*NOTE:  
DESIGNED TO WITHSTAND  
H-20 WHEEL LOADINGS.  
SUITABLE FOR USE IN  
OFF-STREET LOCATIONS  
WHERE NOT SUBJECTED  
TO HIGH DENSITY TRAFFIC.

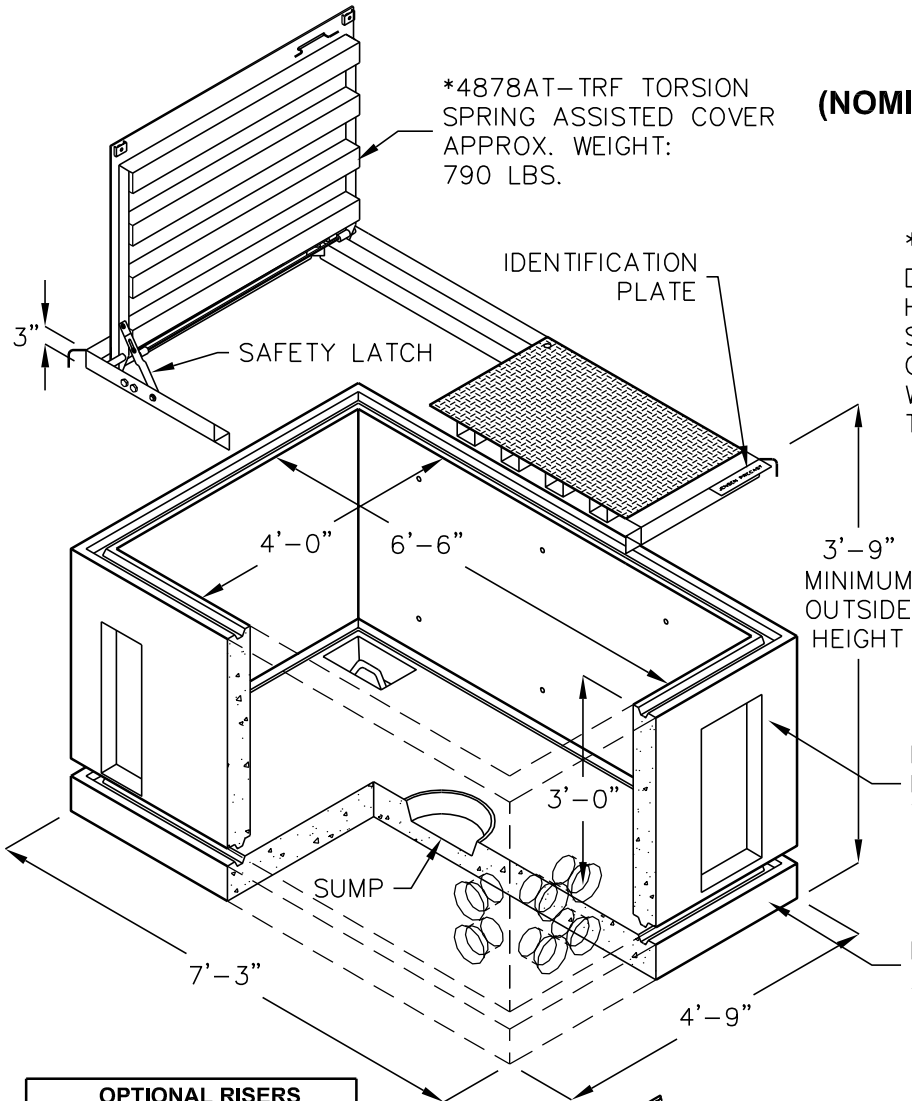

BOX DESIGN LOAD:  
H-20 TRAFFIC  
WEIGHT: 3050 LBS.

BASE WEIGHT:  
2400 LBS.

OPTIONAL RISERS (EXTENSIONS)		
MODEL NO.	B	WEIGHT
466-R6	6"	650 LBS.
466-R12	12"	1190 LBS.

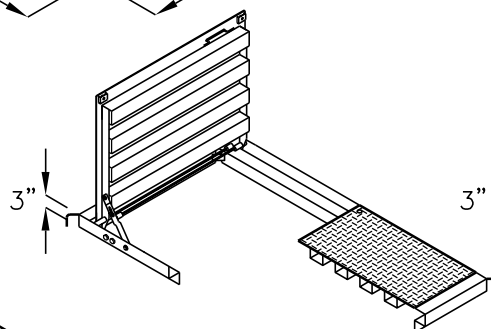
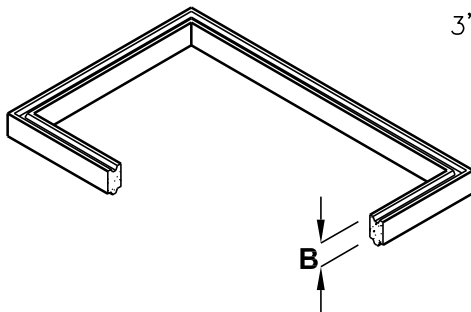

**ADJUSTABLE TORSION SPRING  
ASSISTED COVERS  
(DIAMOND PLATE SURFACE)**

\*4878AT-TRF, 790 LBS.  
(H-20 TRAFFIC)  
OR  
4878AT-PKY, 640 LBS.  
(NON-TRAFFIC)

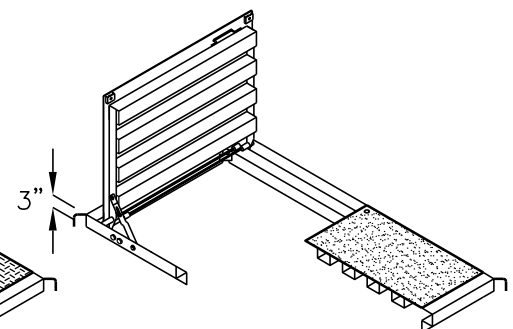

**ADJUSTABLE TORSION SPRING  
ASSISTED COVERS  
(NON-SLIP SURFACE)**

\*4878AT-TRF-AG, 650 LBS.  
(H-20 TRAFFIC)  
OR  
4878AT-PKY-AG, 630 LBS.  
(NON-TRAFFIC)

FOR COMPLETE DESIGN AND PRODUCT INFORMATION,  
CONTACT JENSEN PRECAST.