

2'-6" x 4'-0" LAUSD TRAFFIC FLAT WALL PULL BOX x 36" DEEP

- NOTES:**
- CONCRETE DESIGNED IN ACCORDANCE WITH AASHTO H-20-44 TRAFFIC LOADING USING 5,500 PSI (37.92mpa) COMPRESSIVE STRENGTH CONCRETE AND 80,000 PSI (5,518 MPa) YIELD STRENGTH ASTM A-708 STEEL REINFORCEMENT PER CALCS. #31646.
 - COVER DESIGNED FOR H-20-44 TRAFFIC LOADING. PER CALC. #31645.
 - PULL BOX TO BE PLACED ON A 6" BASE OF CRUSHER RUN FOR EASE OF INSTALLATION AND EVEN LOAD DISTRIBUTION.
- COVERING INFORMATION:**
- K3048-FP36-23T (LAUSD) FOR ASSEMBLY AS SHOWN. TOTAL WEIGHT FOR ASSEMBLY AS SHOWN 2,487 Lbs.

- PR3048F-830-05, 30" BOTTOM SECTION. WT. 2,124 Lbs.
- FR3048-16E, TOP SECTION, W/(FR3048-PB-ANG) GALV.
- ANGLE FRAME, WT. 213 Lbs. TRAFFIC COVER W/(6) 1/2" x 13X6 X SC3048-FSRGV, ONE PIECE TRAFFIC COVER W/(6) 1/2" x 13X6 X 1/2" DIA. SS316, BOLTS. (2) PICK HOLES. SLIP RESISTANT GALV. COVER
- 6" x 7/8" DIA. SUMP x 4" DEEP, BOTTOM SECTION
- (1) CORE MTD.
- 20" x 20" KNOCKOUT x 3" DEEP, DRAFT AS BUILT. 8" DIA. SUMP x 3" DEEP, BOTTOM SECTION (2) SHELL MTD.
- 8" DIA. SUMP x 3" DEEP, BOTTOM SECTION (4) SHELL MTD. 1" DIA. BLIND THRU GROUND ROD HOLE, BOTTOM SECTION (2) CORE MTD.
- 7/8" DIA. PULL IRON, BOTTOM SECTION (2) CORE MTD.
- 1/2" P-35-T INSERT W/CLEAN-OUT HOLE, TOP SECTION (6) FRAME MTD.
- 1/2" P-35-T INSERT, TOP SECTION (2) SHELL MTD.
- 1/2" P-35-T INSERT, TOP SECTION (2) SHELL MTD.
- 1/2" PLASTIC RACKING INSERTS, BOTTOM SECTION (8) CORE MTD.

- GENERAL NOTES:**
- Minimum soil bearing capacity is hereby assumed to be 2000 PSF unless otherwise indicated by a geotechnical report that has been provided to Jensen Precast by the end user. Jensen Precast shall not be held responsible for the soil bearing capacity.
 - Installation of Manholes, Vaults, Handholes, Meter Boxes etc. will be as per Jensen installation procedures.
 - Structural modification to the Jensen line of products is not permitted without prior written approval from Jensen Engineering Department. Do not scale the drawings, verify all dimensions including rough openings, if any discrepancies are found, notify the Jensen Engineer immediately.
 - The Jensen Engineer will interpret the intent of the drawings in case of possible conflict or discrepancy.
 - Permissible Variations:**
Dimensional Tolerances — The length, width, height, or dia. measurements of the structure shall be measured on the outside face unless the drawing deviate form design dimensions by more than the following:
Tolerance: 1/4"
Dimensions: 0 to 5 Feet 3/8"
5 to 10 Feet 5/8"
10 to 20 Feet as agreed upon between the supplier and purchaser.
Squareness Tolerance:
The inside of the precast concrete component shall be square as determined by diagonal measurements. The difference between such measurements shall not exceed the following:
Measured Length: Allowable Difference 0 to 10 Feet 1/2"
10 to 20 Feet 3/4"
20 Feet and over as agreed upon between the supplier and purchaser.

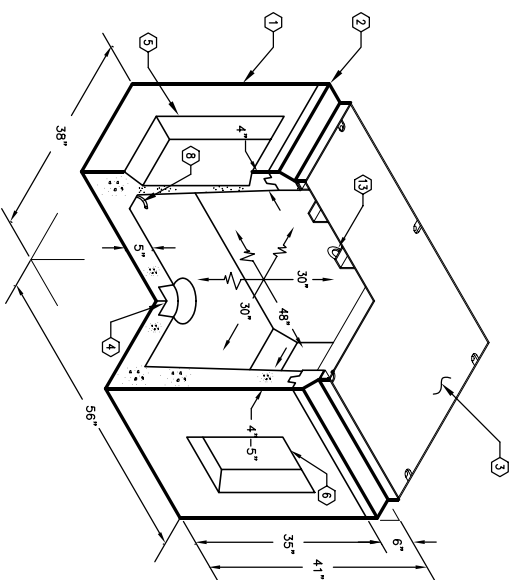

K3048-FP36-23T
LAUSD
03-01-02

MINIMUM EXCAVATION SIZE:
3'-8" x 3'-2" x 18" MIN. REQ'D.

JENSEN PRECAST

DATE	DESCRIPTION	BY

K3048-FP36-23T
LAUSD
03-01-02

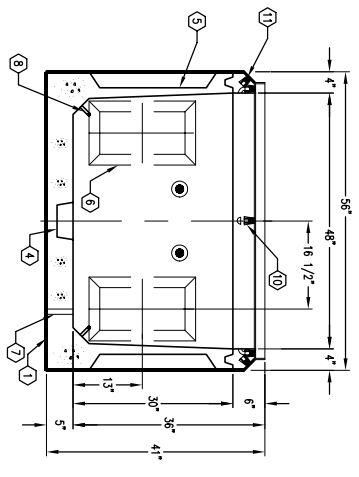

SECTION A-A

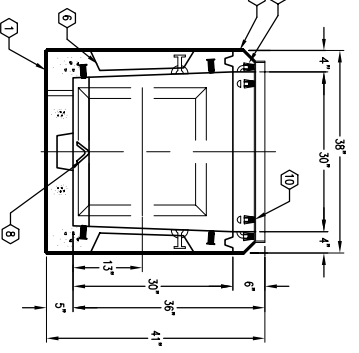

SECTION B-B

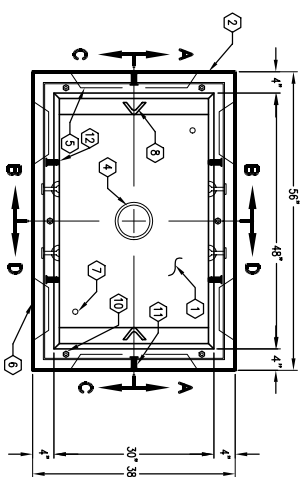

PLAN VIEW

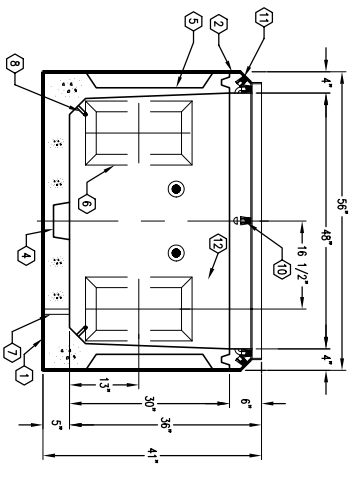

SECTION C-C

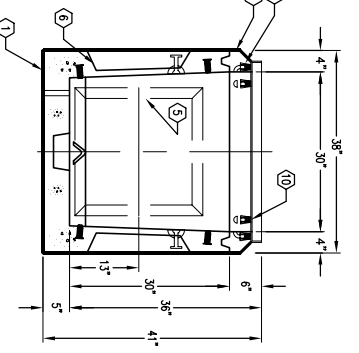

SECTION D-D