

4'-0" x 6'-6" LADWP DUCTED VAULT x 112" DEEP

NOTES:

- VAULT DESIGNED IN ACCORDANCE WITH AASHTO H-20-44 TRAFFIC BRIDGE LOADING USING 5,500 PSI [37.92MPa] COMPRESSIVE STRENGTH CONCRETE AND 60,000 PSI [413.2MPa] YIELD STRENGTH ASTM A-706 STEEL REINFORCEMENT PER CALCS. #31597.
- VAULT TO BE PLACED ON A MIN. 6" BASE OF CRUSHER RUN FOR EASE OF INSTALLATION AND EVEN LOAD DISTRIBUTION.
- CONCRETE MIX USED IN POURING THIS PRODUCT SHALL USE FLY ASH AS IN ADMIXTURE.
- EACH CONCRETE SECTION SHALL BE MARKED ON THE INSIDE & OUTSIDE WITH "JENSEN PRECAST", THE DESIGNATION "DWP/FA.", AND THE DATE OF POUR.
- EACH CONCRETE SECTION SHALL HAVE CAST-IN ON THE INSIDE "JENSEN", THE YEAR, AND THE DESIGNATION "FA."

THE FOLLOWING MATERIAL TO BE SHIPPED WITH VAULT:

- (a) 7/8" x 1 3/4" CONSEAL GASKET (45 FT. REQ'D).

ORDERING INFORMATION:

K466-DV112-12 FOR ASSEMBLY AS SHOWN.
 PER LADWP SPEC G-291 G7, R20.
 TOTAL WEIGHT OF ASSEMBLY SHOWN IS 20,912 Lbs.

1. PB466-B40-12, 40" BOTTOM SECTION, WT. 9,031 Lbs.
2. UV466-T72-12, 72" ROOF SECTION, WT. 11,881 Lbs.
3. 12" x 13" DIA. SLUMP x 5" DEEP WITH RECESS. LOCATE AS FOLLOWS: BOTTOM SECTION (1) CORE MTD.
4. 16" x 44" DUCTED, K.O. x 12" DEEP. DRAFT AS FOLLOWS: T=1", S1=S2=5", B=7". LOCATE AS FOLLOWS: ROOF SECTION (2) CORE MTD.
5. 9" x 18" K.O. x 4" DEEP. DRAFT AS FOLLOWS: ROOF SECTION (4) CORE MTD.
6. 12" x 14" VENT K.O. x 5" DEEP. LOCATE AS FOLLOWS: ROOF SECTION (2) CORE MTD.
7. 7/8" DIA. PULL IRON. LOCATE AS FOLLOWS: BOTTOM SECTION (1) CORE MTD.; ROOF SECTION (8) CORE MTD.
8. 1 1/2" PLASTIC INSERT. LOCATE AS FOLLOWS: ROOF SECTION (6) CORE MTD.
9. 1" DIA. TERMS W/5/8" DIA. GROUND ROD KNOCKOUT. LOCATE AS FOLLOWS: BOTTOM SECTION (8) CORE MTD.
10. 12" DIA. KNOCKOUT. LOCATE AS FOLLOWS: BOTTOM SECTION (2) CORE MTD.
11. CORE MTD.

GENERAL NOTES:

1. Minimum soil bearing capacity is hereby assumed to be 2000 PSF unless otherwise documented by a geotechnical report that shall be provided to Jensen Precast by the end user. Jensen Precast shall not be held responsible for the soil bearing capacity.
2. Installation of Manholes, Vaults, Handholes, Meter Boxes etc. will be as per Jensen installation procedures.
3. Structural modification to the Jensen line of products is not permitted without prior written approval from Jensen Engineering Department.
4. Do not scale the drawings, verify all dimensions including rough openings, if any discrepancies are found, notify the Jensen Engineer immediately.
5. The Jensen Engineer will interpret the intent of the drawings in case of possible conflict or discrepancy.
6. Permissible Variations: Dimensional Tolerances – The length, width, height, or dia. measurements of the structure when measured on the inside surfaces shall not deviate from design dimensions by more than the following: Tolerance: 0 to 5 Feet 1/4" 5 to 10 Feet 3/8" 10 to 20 Feet as agreed upon between the supplier and purchaser. Squariness Tolerance: The inside of the precast concrete component shall be square as determined by diagonal measurements. The difference between such measurements shall not exceed the following: Measured Length: Allowable Difference 0 to 10 Feet 1/2" 10 to 20 Feet 3/4" 20 Feet and over as agreed upon between the supplier and purchaser.
- 7.

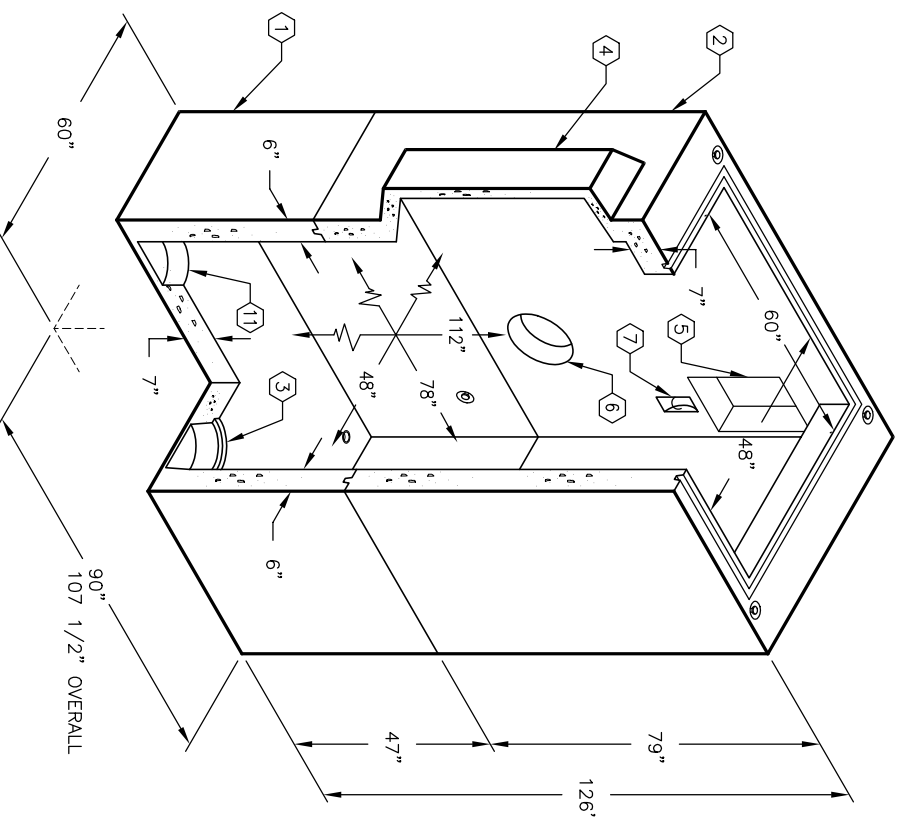

MINIMUM EXCAVATION SIZE:
 6'-0" x 10'-0" x DEPTH REQ'D.

K466-DV112-12

PER LADWP SPEC. G-291 G-7, R20

03-01-02

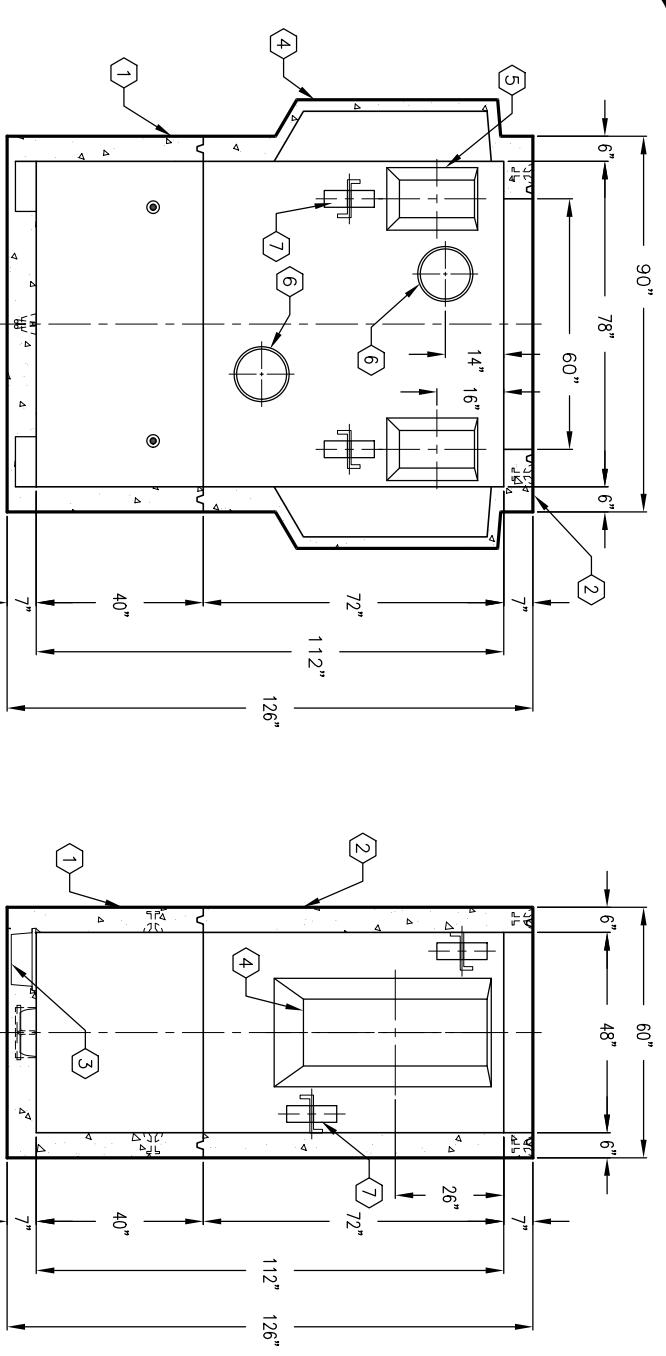

SECTION A-A

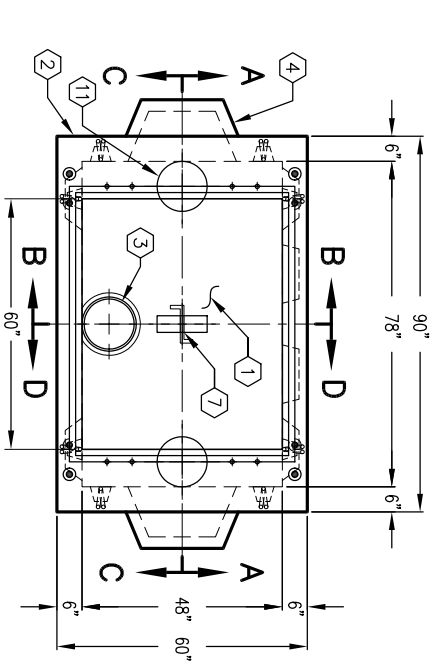

PLAN VIEW

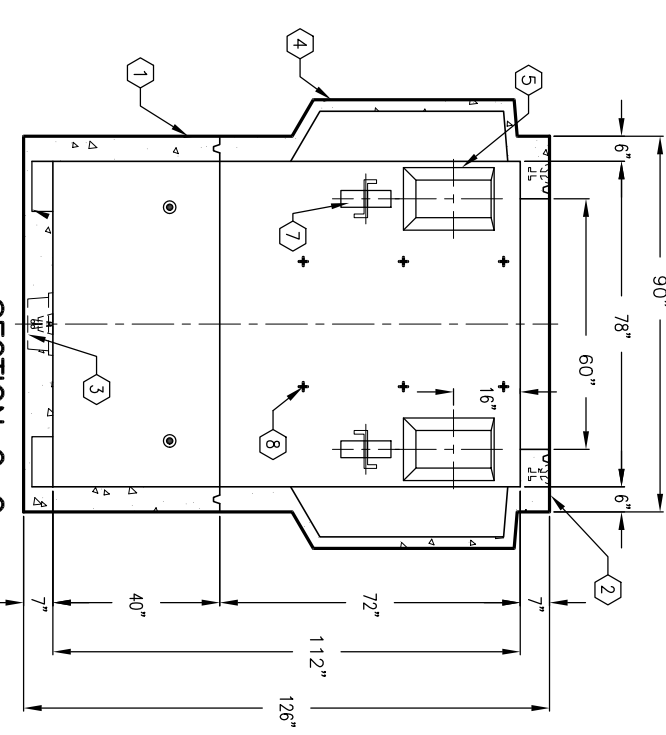

SECTION C-C

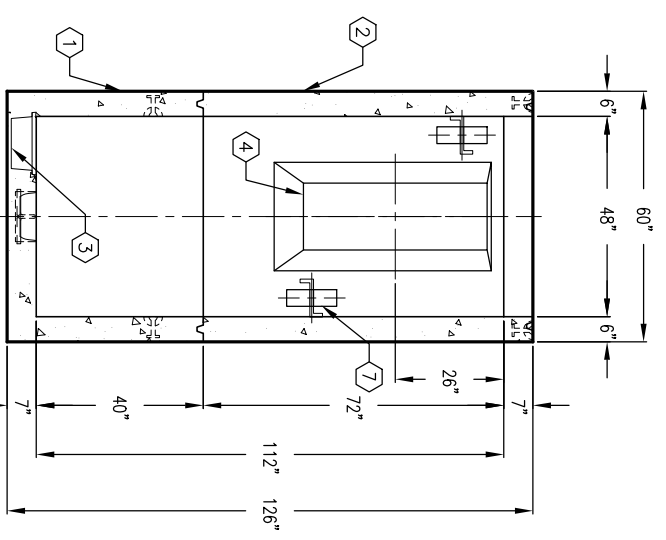

SECTION B-B

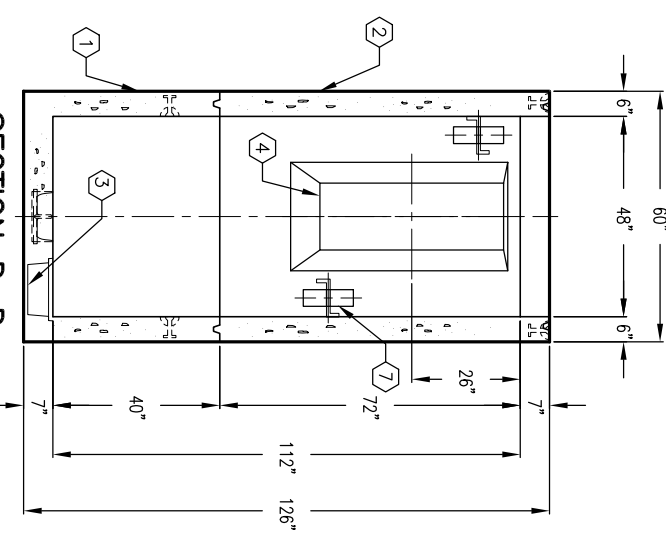

SECTION D-D

JENSEN PRECAST

#	DATE	DESCRIPTION	BY

K466-DV112-12

PER LADWP SPEC. G-291 G-7, R20

03-01-02