

4'-0" x 6'-6" LADWP DUCTED VAULT x 84" DEEP

NOTES:

- VAULT DESIGNED IN ACCORDANCE WITH AASHTO H-20-44 TRAFFIC BRIDGE LOADING USING 5,500 PSI COMPRESSIVE STRENGTH CONCRETE AND 60,000 PSI YIELD STRENGTH ASTM A-706 STEEL REINFORCEMENT PER CALCS. #50387.
- VAULT TO BE PLACED ON A MIN. 6" BASE OF CRUSHER RUN FOR EASE OF INSTALLATION AND EVEN LOAD DISTRIBUTION.
- CONCRETE MIX USED IN POURING THIS PRODUCT SHALL USE FLY ASH AS IN ADMIXTURE.
- EACH CONCRETE SECTION SHALL BE MARKED ON THE INSIDE & OUTSIDE WITH "JENSEN PRECAST," THE DESIGNATION "DWP/FA.", AND THE DATE OF POUR.
- EACH CONCRETE SECTION SHALL HAVE CAST-IN ON THE INSIDE "JENSEN", THE YEAR, AND THE DESIGNATION "FA."

1. PB466-B12-12, 12" BOTTOM SECTION, WT. 4,859#.
2. UV466-T72-12, 72" ROOF SECTION, WT. 11,881#.
3. 12" x 13" DIA. SLUMP x 5" DEEP WITH RECESS. LOCATE AS FOLLOWS: BOTTOM SECTION (1) CORE MTD.
4. 16" x 44" DUCTED, K.O. x 12" DEEP. DRAFT AS FOLLOWS: T=1", S1=S2=5", B=7". LOCATE AS FOLLOWS: ROOF SECTION (2) CORE MTD.
5. 9" x 18" K.O. x 4" DEEP. DRAFT AS FOLLOWS: T=1" S1=S2=3", B=3". LOCATE AS FOLLOWS: ROOF SECTION (4) CORE MTD.
6. 12" x 14" VENT K.O. x 5" DEEP. LOCATE AS FOLLOWS: ROOF SECTION (2) CORE MTD.
7. 7/8" DIA. PULL IRON (05-2140). LOCATE AS FOLLOWS: BOTTOM SECTION (1) CORE MTD.; ROOF SECTION (8) CORE MTD.
8. 1 1/2" PLASTIC INSERT. LOCATE AS FOLLOWS: INTERMEDIATE SECTION (6) CORE MTD.
9. 1" DIA. TERMS W/5/8" DIA. GROUND ROD KNOCKOUT. LOCATE AS FOLLOWS: BOTTOM SECTION (8) CORE MTD.
10. 12" DIA. KNOCKOUT. LOCATE AS FOLLOWS: BOTTOM SECTION (2) CORE MTD.
11. CORE MTD.

THE FOLLOWING MATERIAL TO BE SHIPPED WITH VAULT:

- (a) 7/8" x 1 3/4" CONSEAL GASKET (69 FT. REQ'D).

ORDERING INFORMATION:

K466-DV84-12 FOR ASSEMBLY AS SHOWN.
 PER LADWP SPEC G-291 G-3, R19.
 TOTAL WEIGHT OF ASSEMBLY SHOWN IS 16,740#.

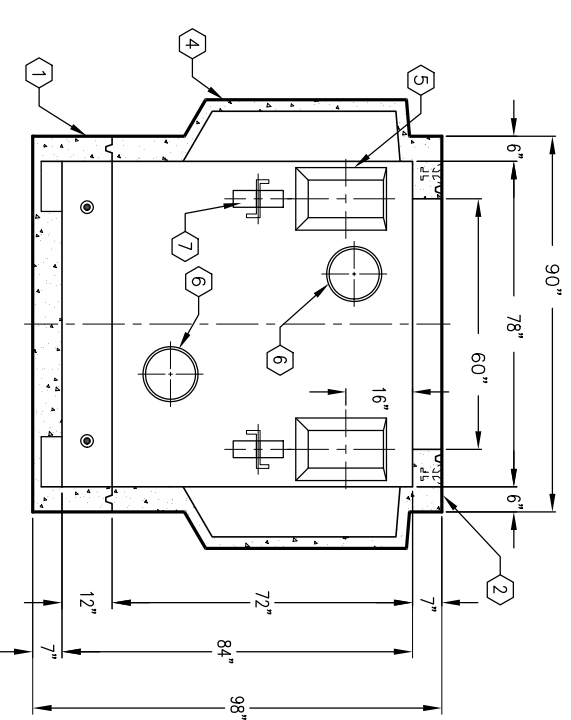
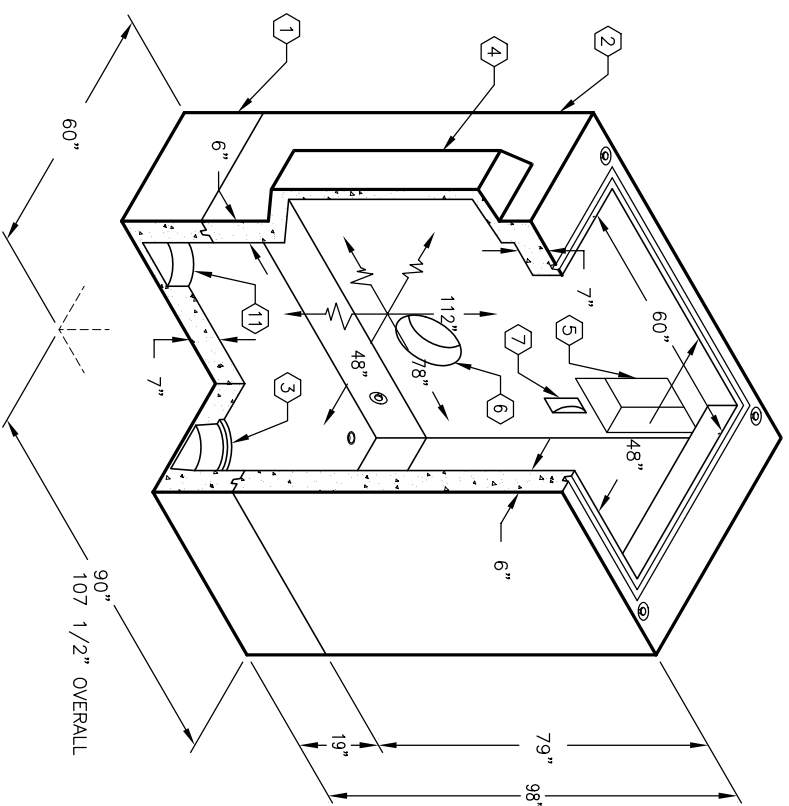

SECTION A-A

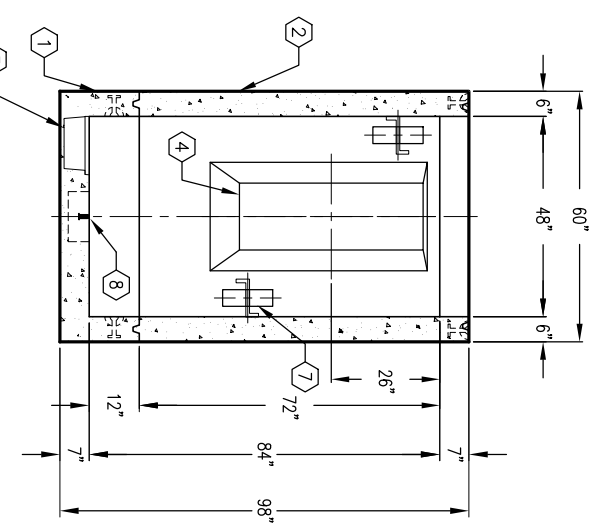

SECTION B-B

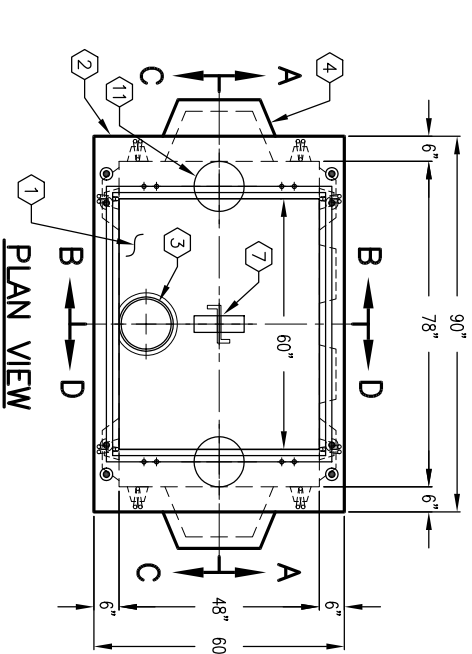

PLAN VIEW

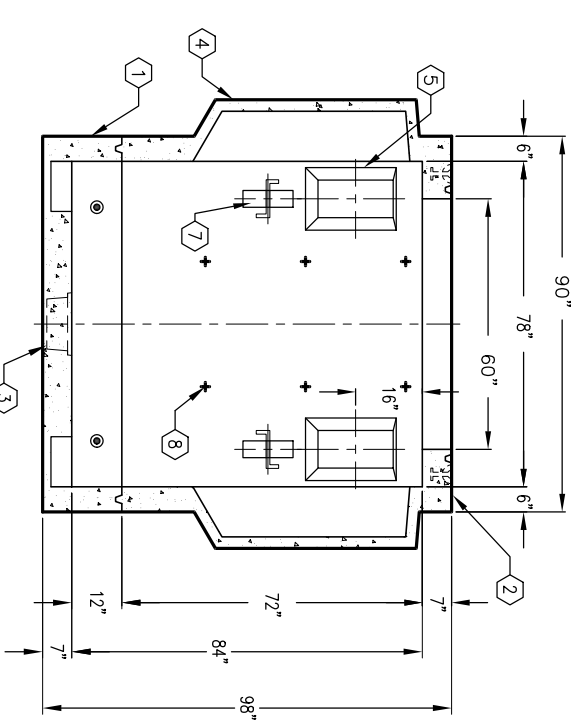

SECTION C-C

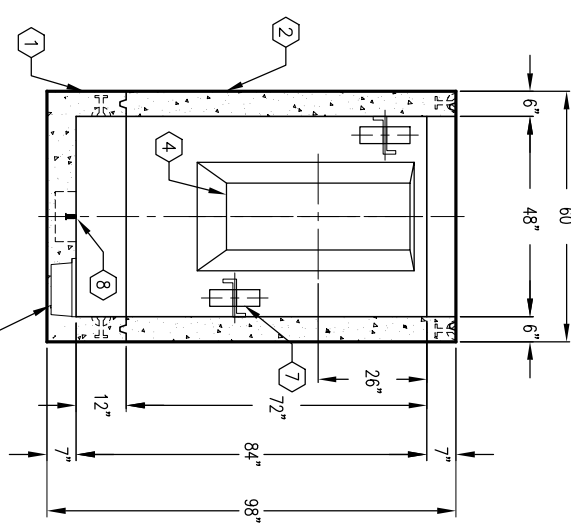

SECTION D-D



AUTOCAD REL. 14

K466-DV84-12

PER LADWP SPEC. G-291 G-3, R19

03-01-02



K466-DV84-12

PER LADWP SPEC. G-291 G-3, R19

03-01-02

#	DATE	DESCRIPTION	BY