

4'-0" x 6'-6" LADWP TRAFFIC SERVICE VAULT x 42" DEEP

NOTES:

- HANDHOLE DESIGNED IN ACCORDANCE WITH AASHTO HS 20-44 TRAFFIC LOADING USING 5,500 PSI [37.92MPa] COMPRESSIVE STRENGTH CONCRETE AND 60,000 PSI [413.2MPa] YIELD STRENGTH ASTM A-706 STEEL REINFORCEMENT PER CALCS. #30222.
- COVER MANUFACTURED IN ACCORDANCE WITH THE CITY OF LOS ANGELES DEPARTMENT OF WATER AND POWER DRAWING #C5072-2. COVER DESIGNED PER CALCS. #31613
- HANDHOLE DESIGNED AND MANUFACTURED IN ACCORDANCE WITH CITY OF LOS ANGELES DEPARTMENT OF WATER AND POWER DRAWING #C-5181-RS.
- HANDHOLE TO BE PLACED ON A 6" BASE OF CRUSHER RUN FOR FASE OF INSTALLATION AND EVEN LOAD DISTRIBUTION.
- CONCRETE MIX USED IN THIS PRODUCT SHALL USE FLY-ASH AS AN ADMIXTURE.
- EACH CONCRETE SECTION SHALL BE MARKED ON THE INSIDE & OUTSIDE WITH "JENSEN PRECAST", THE DESIGNATION "DWP/FA.", AND THE DATE OF POUR.
- EACH CONCRETE SECTION SHALL HAVE CAST-IN ON THE INSIDE "JENSEN", THE YEAR, AND THE DESIGNATION "FA".

THE FOLLOWING MATERIAL TO BE SHIPPED WITH EACH VAULT:
(0) 7/8" x 1 3/4" CONSEAL GASKET (90 FT. REQ'D.)

GENERAL NOTES:

1. Minimum soil bearing capacity is hereby assumed to be 2000 PSF unless otherwise documented by a geotechnical report that shall be provided to Jensen Precast by the end user. Jensen Precast shall not be held responsible for the soil bearing capacity.
2. Installation of Manholes, Vaults, Handholes, Meter Boxes etc. will be as per Jensen installation procedures.
3. Structural modification to the Jensen line of products is not permitted without prior written approval from Jensen Engineering Department.
4. Do not scale the drawings, verify all dimensions including rough openings, if any discrepancies are found, notify the Jensen Engineer immediately.
5. The Jensen Engineer will interpret the intent of the drawings in case of possible conflict or discrepancy.
6. Permissible Variations:
Dimensional Tolerances - The length, width, height, or dia. measurements of the structure when measured on the inside surfaces shall not deviate from design dimensions by more than the following:
Tolerance: 1/4"
0 to 5 Feet 3/8"
5 to 10 Feet 1/2"
10 to 20 Feet as agreed upon between the supplier and purchaser.
Squareness Tolerance:
The inside of the precast concrete component shall be square as determined by diagonal measurements. The difference between such measurements shall not exceed the following:
Measured Length: Allowable Difference 1/2"
0 to 10 Feet 3/4"
10 to 20 Feet as agreed upon between the supplier and purchaser.
- 7.

1. PB466-B-12, 7" THICK BASE SLAB. WT. 3,346 Lbs.
2. PB466-124-12, 24" INTERMEDIATE SECTION. WT. 3,539 Lbs.
3. PB466-R18-12, 18" EXTENSION SECTION. WT. 2,640 Lbs.
4. PB466-T12-123, 12" THICK TOP SLAB. WT. 3,280 Lbs.
5. L.A. #3, TWO PIECE TRAFFIC HINGED COVER W/(2) 6 3/8" DIA. READING LIDS, RED PRIMER FINISH, CAST INTO TOP SLAB. COVERS MARKED WITH THE WORDS "LA WATER". No. 3 WT. 669 Lbs.
6. 14" x 15" DIAMETER SUMP x 7" DEEP. LOCATE AS FOLLOWS:
FOLLOWS: BASE SLAB (1) TABLE MTD.
10 1/2" x 12" THRU OPENING. LOCATE AS FOLLOWS: INTERMEDIATE SECTION (2) CORE MTD.
7. 3/4" x 2 1/2" COIL THREAD GALVANIZED INSERT W/NUT x 4" WIDE. LOCATE AS FOLLOWS: TOP SLAB (4) SURFACE MTD., (4) PALLET MTD.

ORDERING INFORMATION:

K466-FH42-12 FOR ASSEMBLY AS SHOWN.
PER LADWP SPEC C-5181, R5
TOTAL WEIGHT OF ASSEMBLY IS 14,805 Lbs.

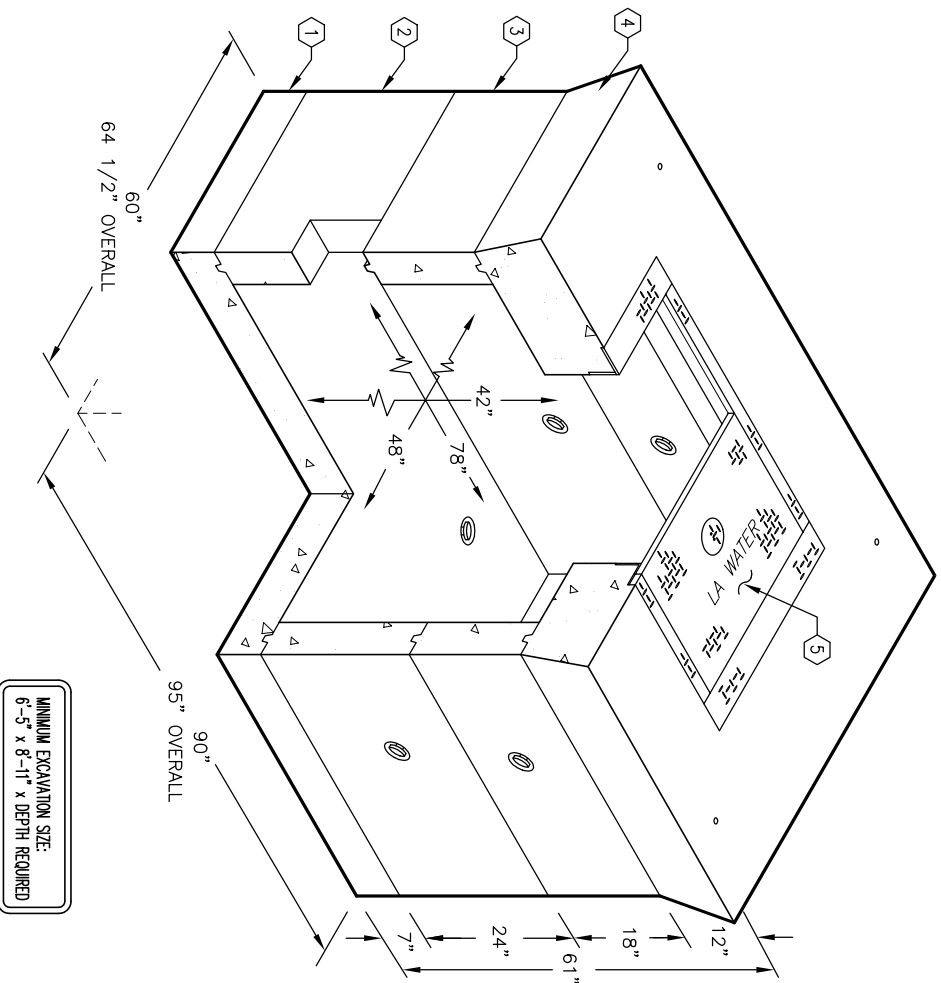

MINIMUM EXCAVATION SIZE:
6'-5" x 8'-11" x DEPTH REQUIRED

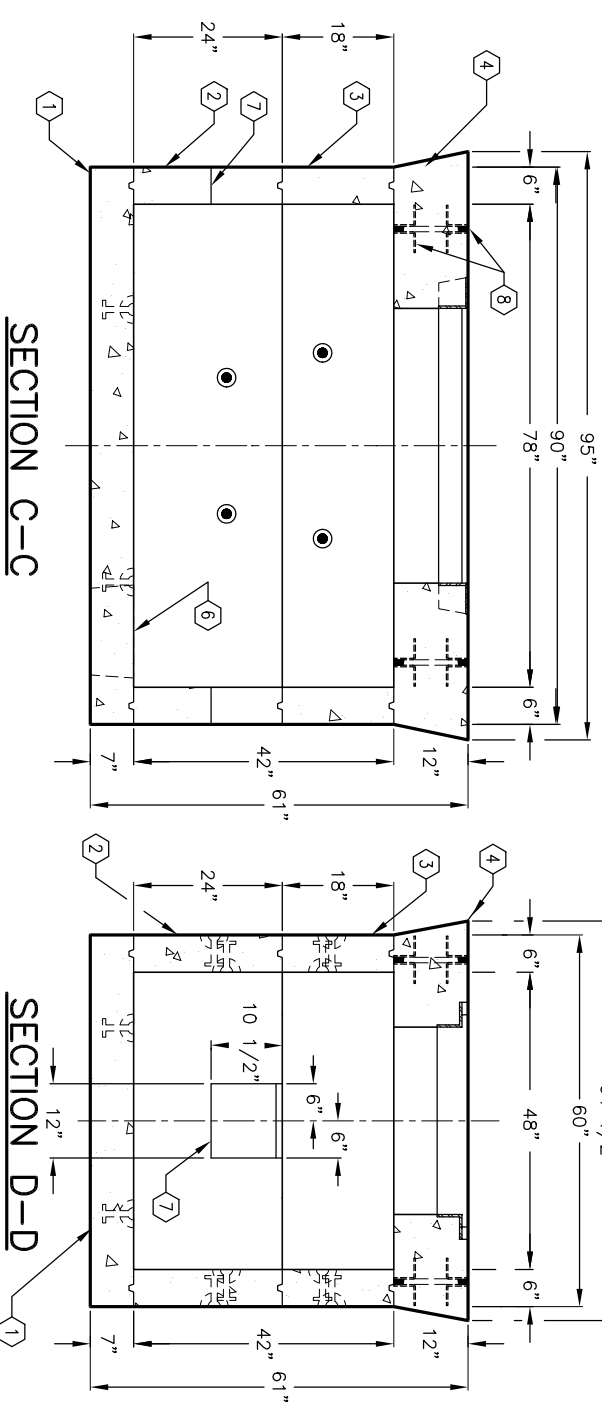
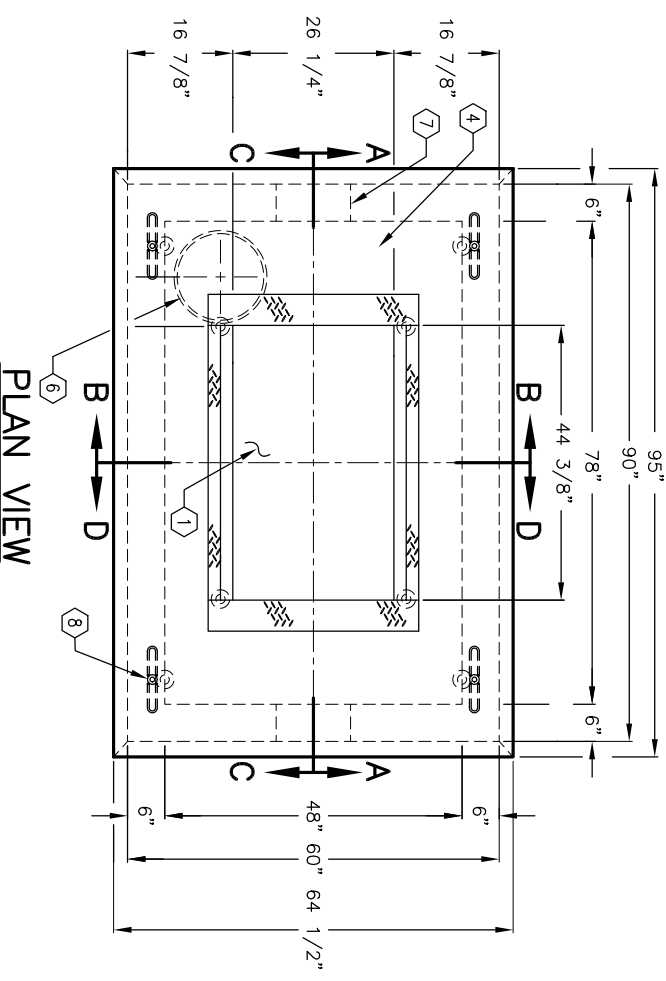
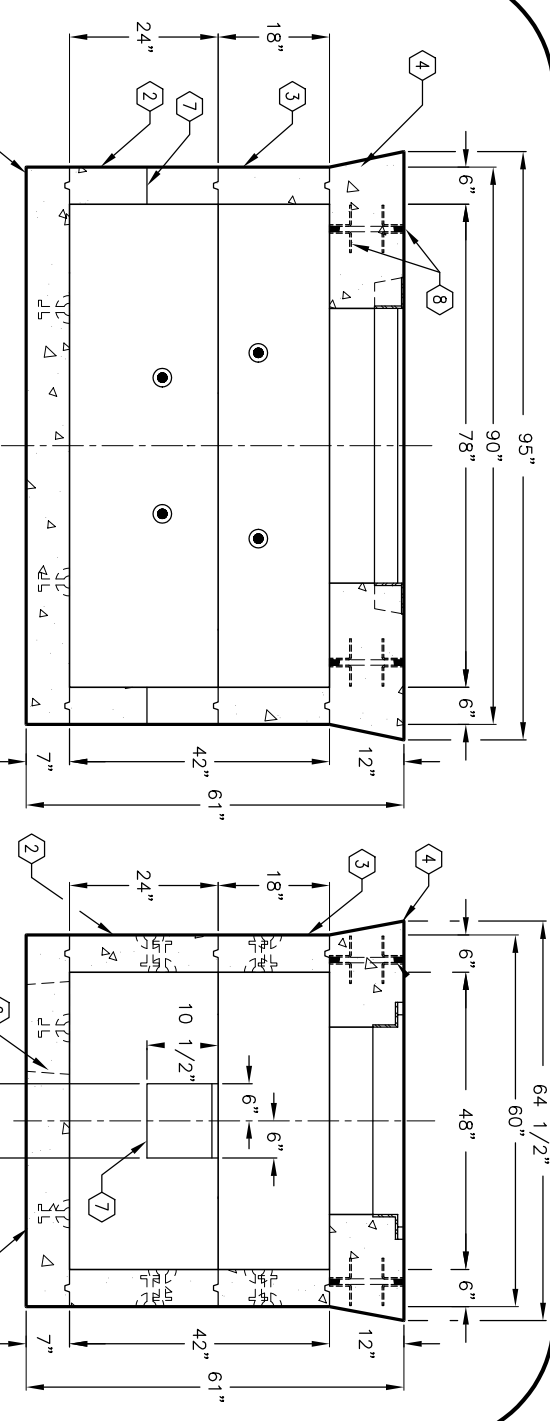

K466-FH42-12

PER LADWP SPEC C-5181, R5

03-01-02

JENSEN PRECAST

#	DATE	DESCRIPTION	BY

K466-FH42-12

PER LADWP SPEC C-5181, R5

03-01-02