

2'-0" x 3'-0" LADWP PARKWAY DUCTED PULL BOX x 3'-0" DEEP

NOTES:

- PULL BOX DESIGNED IN ACCORDANCE WITH AASHTO H-20-44 TRAFFIC BRIDGE LOADING USING 5,500 PSI [37.92MPa] COMPRESSIVE STRENGTH CONCRETE AND 60,000 PSI [413.2MPa] YIELD STRENGTH ASTM A-706 STEEL REINFORCEMENT PER CALC. #316533.
 - COVER DESIGNED FOR PARKWAY LOADING @ 300 PSF PER CALC. #313553
 - PULL BOX TO BE PLACED ON A MIN. 6" BASE OF CRUSHER RUN FOR EASE OF INSTALLATION AND END LOAD DISTRIBUTION.
 - CONCRETE MIX USED IN POURING THIS PRODUCT SHALL USE 7. FLY-ASH AS AN ADMIXTURE.
 - EACH CONCRETE SECTION SHALL BE MARKED ON THE INSIDE & OUTSIDE WITH "JENSEN PRECAST", THE DESIGNATION "DWP/FA.", AND THE DATE OF POUR.
 - EACH CONCRETE SECTION SHALL HAVE CAST-IN ON THE INSIDE "JENSEN", THE YEAR, AND THE DESIGNATION "FA."
1. PB2436D-B30-12, 30" BOTTOM SECTION, WT. 1,822 Lbs.
 2. PB2436-16-12, 6" TOP SECTION, W/F2436-PB-ANG. FRAME CAST IN, WT. 185 Lbs.
 3. ONE PIECE PARKWAY POLYMER CONCRETE COVER W/ (4) 1/2" x 13 x 2 1/2" S.S. HEX HEAD BOLT-DOWNS, (2) PICK HOLES, MARK "LADWP-E.", WT. 134 Lbs.
 4. 1/2" x 5" ADJUSTING BOLT W/NUT ASSEMBLY, TOP SECTION (4) CORE MTD.
 5. 6" x 7" DIA. SUMP x 4" DEEP, BOTTOM SECTION (1) CORE MTD.
 6. 11" x 11" DUCTED K.O. x 13 1/2" DEEP, DRAFT AS FOLLOWS: I=6", S1=S2=5", B=0". BOTTOM SECTION (2) CORE MTD.
 7. 8" x 16" K.O. x 3" DEEP, DRAFT 2" ALL SIDE TYP. BOTTOM SECTION (4) SHELL MTD.
 8. 1" DIA. BLIND GROUND ROD HOLE, BOTTOM SECTION (2) CORE MTD.
 9. + 1/2" PLASTIC INSERT, BOTTOM SECTION (8) CORE MTD.
 10. 1/2" P-35-T INSERT W/CLEAN-OUT HOLE, TOP SECTION (4) FRAME MTD.
 11. @ 1/2" P-36-T INSERT, TOP SECTION (2) SHELL MTD.
 12. 7/8" DIA. X 9" VERTICAL GALV. PULL IRON, BOTTOM SECTION (2) CORE MTD.

ORDERING INFORMATION:

K2436-DP36-12P FOR ASSEMBLY AS SHOWN.
TOTAL WEIGHT OF ASSEMBLY SHOWN IS 2,150 LBS.

GENERAL NOTES:

1. Minimum soil bearing capacity is hereby assumed to be 2000 PSF unless otherwise documented by a geotechnical report that shall be provided to Jensen Precast by the end user. Jensen Precast shall not be held responsible for the soil bearing capacity. Installation of Manholes, Vaults, Handholes, Meter Boxes etc. will be as per Jensen Installation procedures.
2. Structural modification to the Jensen line of products is not permitted without prior written approval from Jensen Engineering Department.
3. Do not scale the drawings, verify all dimensions including rough openings, if any discrepancies are found, notify the Jensen Engineer immediately.
4. The Jensen Engineer will interpret the intent of the drawings in case of possible conflict or discrepancy.
5. Permissible Variations: - The length, width, height, or dia. measurements of the structure when measured on the inside surfaces shall not deviate from design dimensions by more than the following:
Tolerance:
0 to 5 Feet 1/4"
5 to 10 Feet 3/8"
10 to 20 Feet as agreed upon between the supplier and purchaser.
Squariness Tolerance:
The inside of the precast concrete component shall be square as determined by diagonal measurements. The difference between such measurements shall not exceed the following:
Measured Length: Allowable Difference
0 to 10 Feet 1/2"
10 to 20 Feet 3/4"
between the supplier and purchaser.

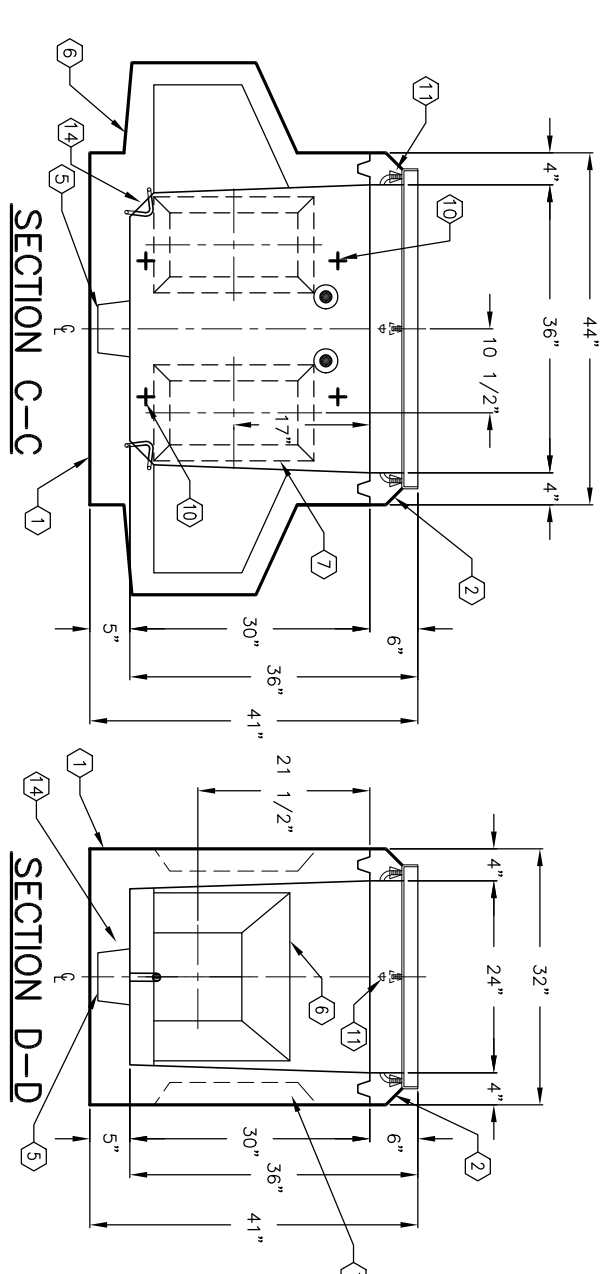
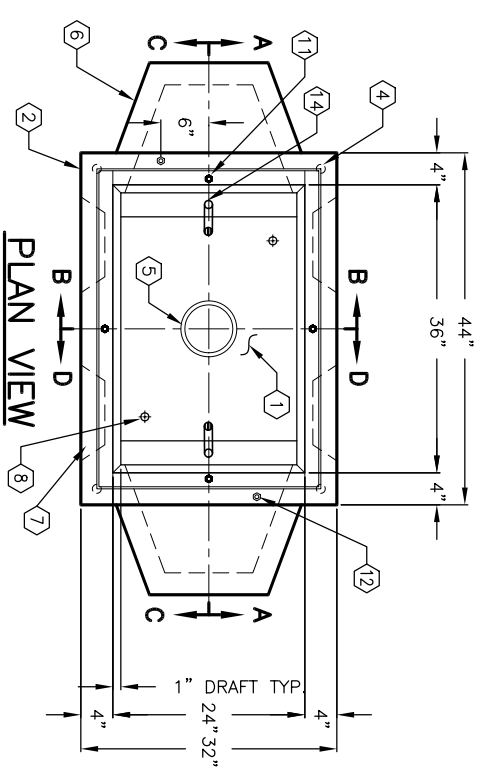
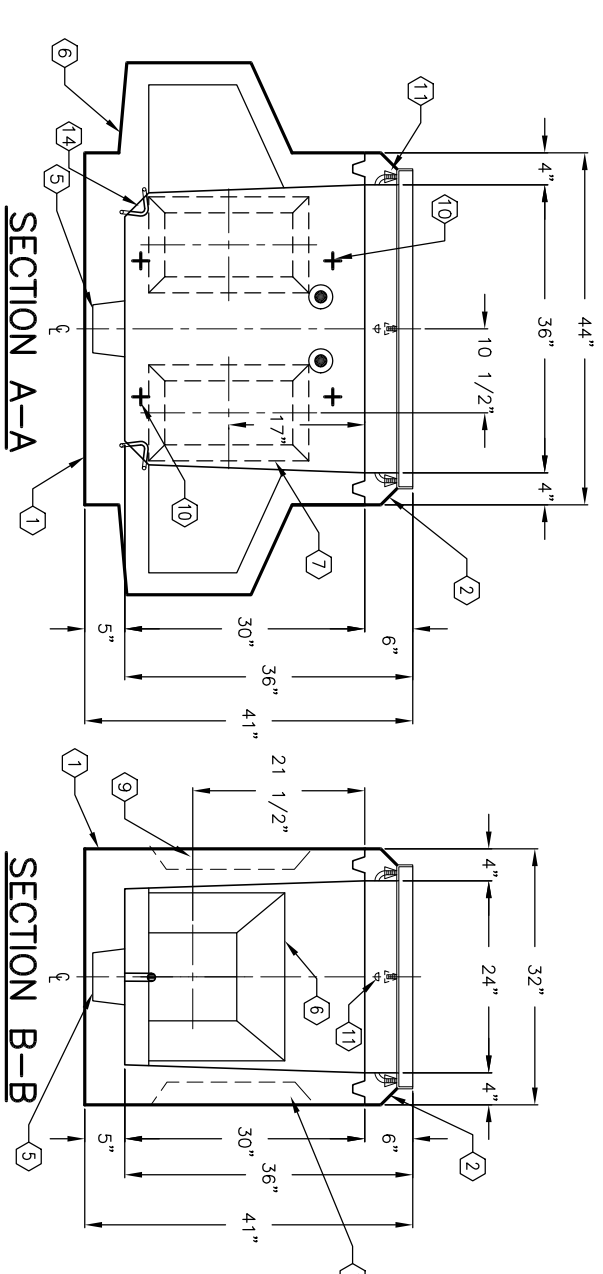
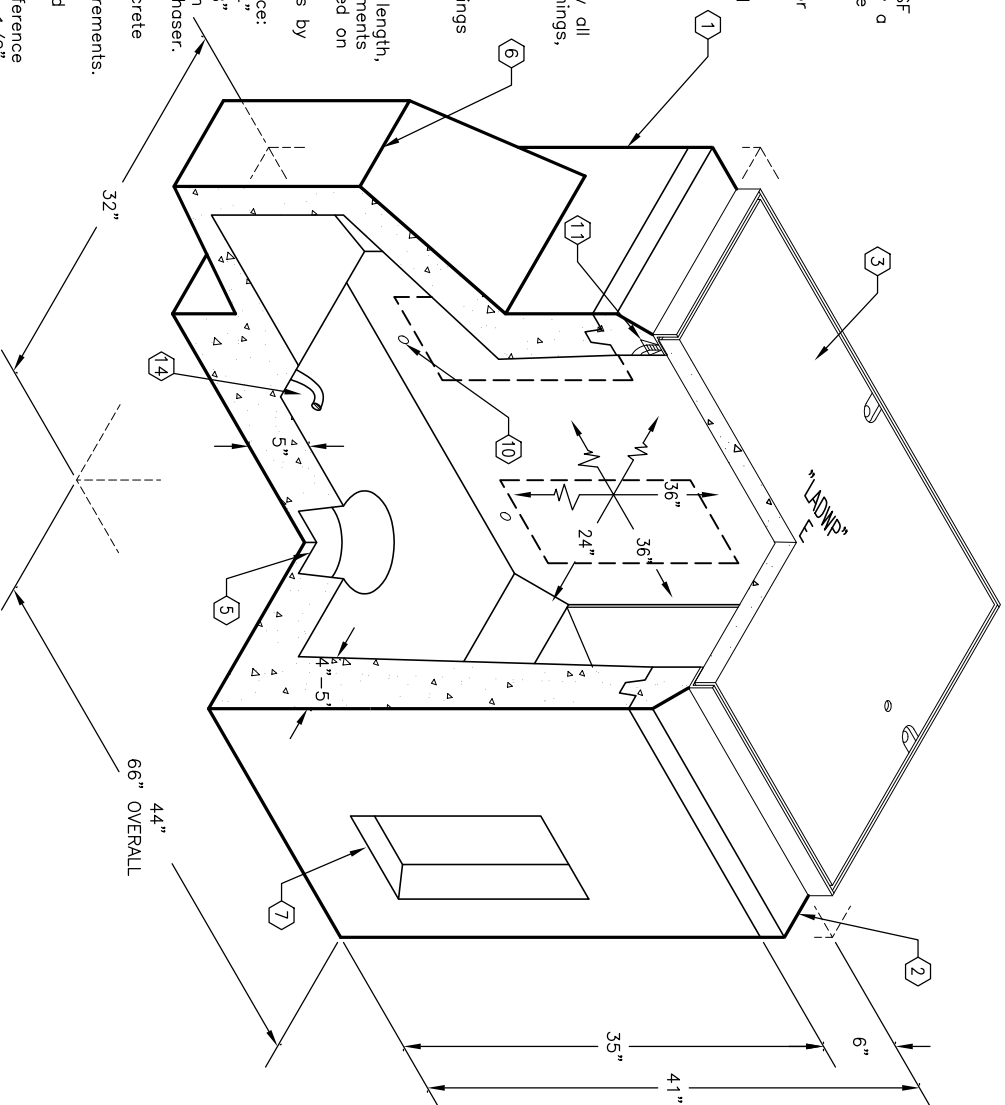

#	DATE	DESCRIPTION	BY