

2'-0" x 3'-0" LADWP PARKWAY DUCTED INTERCEPT PULL BOX x 3'-0" DEEP

NOTES:

- CONCRETE DESIGNED FOR H-20-44 TRAFFIC BRIDGE LOADING USING 5,500 PSI [37.92MPa] COMPRESSIVE STRENGTH CONCRETE AND 60,000 PSI [413.2MPa] YIELD STRENGTH ASTM A-706 REINFORCING STEEL PER CALC. #31633.
- COVER DESIGNED FOR PARKWAY LOADING @ 300 PSF PER CALC. #31353
- INTERCEPT BOX TO BE PLACED ON A 6" BASE OF CRUSHER RUN FOR EVEN LOAD DISTRIBUTION AND EASE OF INSTALLATION.
- CONCRETE MIX USED IN POURING THIS PRODUCT SHALL USE FLY-ASH AS AN ADMIXTURE.
- EACH CONCRETE SECTION SHALL BE MARKED ON THE INSIDE & OUTSIDE WITH "JENSEN PRECAST" THE DESIGNATION "DWP/FA.", AND THE DATE OF POUR.
- EACH CONCRETE SECTION SHALL HAVE CAST-IN ON THE INSIDE "JENSEN", THE YEAR, AND THE DESIGNATION "FA."

ORDERING INFORMATION:

K2436-DI36-12P FOR ASSEMBLY AS SHOWN.
TOTAL ASSEMBLY WT. 2,182 Lbs.

GENERAL NOTES:

1. Minimum soil bearing capacity is hereby assumed to be 2000 PSF unless otherwise documented by a geotechnical report that shall be provided to Jensen Precast by the end user. Jensen Precast shall not be held responsible for the soil bearing capacity.
2. Handholes, Meter Boxes, Vaults, Installation of Manholes, Vaults, etc. will be as per Jensen installation procedures.
3. Structural modification to the Jensen line of products is not permitted without prior written approval from Jensen Engineering Department.
4. Do not scale the drawings, verify all dimensions including rough openings, if any discrepancies are found, notify the Jensen Engineer immediately.
5. The Jensen Engineer will interpret the intent of the drawings in case of possible conflict or discrepancy.
6. Permissible Variations: Dimensional Tolerances – The length, width, height, or dia. measurements of the structure when measured on the inside surfaces shall not deviate from design dimensions by more than the following:
Dimensions: Tolerance:
0 to 5 Feet 1/4"
5 to 10 Feet 3/8"
10 to 20 Feet as agreed upon between the supplier and purchaser.
7. Squariness Tolerance: he inside of the precast concrete component shall be square as determined by diagonal measurements. The difference between such measurements shall not exceed the following:
Measured Length: Allowable Difference
0 to 10 Feet 1/2"
10 to 20 Feet 3/4"
20 Feet and over as agreed upon between the supplier and purchaser.

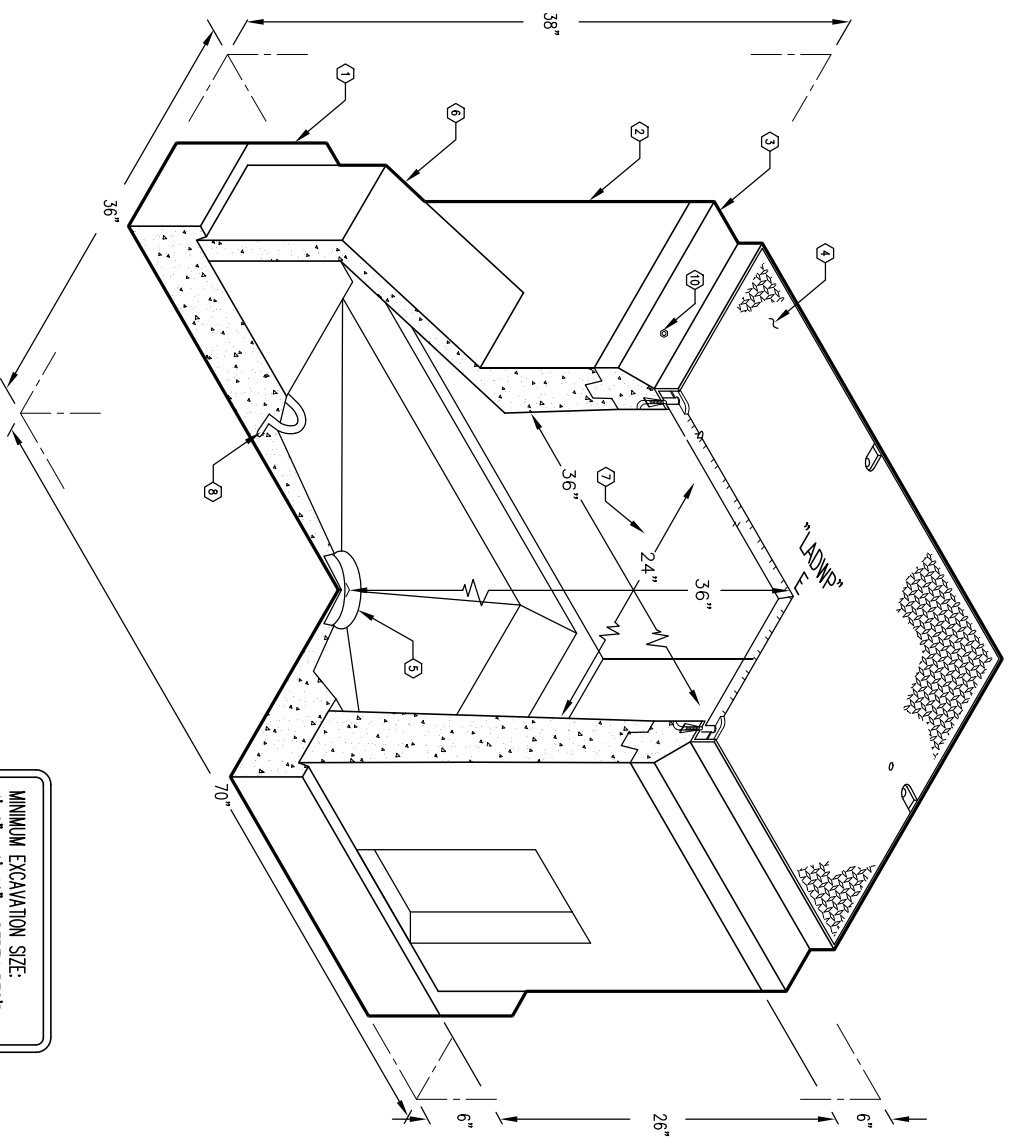

MINIMUM EXCAVATION SIZE:
4'-0" x 6'-10" x DEPTH REQD.

1. PB2436-B-12, 3" BASE SLAB, WT. 953 lbs.
2. PB2436D-127-12, 27" INTERMEDIATE SECTION, WT. 951 lbs.
3. PB2436-T6-12, 6" TOP SECTION, W/ (F2436-PB-ANG) GALV. FRAME CAST IN, WT. 182 lbs.
4. ONE PIECE PARKWAY POLYMER CONCRETE COVER, (2) PICK HOLES, (4) 1/2"-13NC x 2 1/2" S.S.H.H. BOLTS, MARK "LADWP-E". WT. 96 lbs.
5. 6" x 6 1/2" DIA. SUMP x 1" DEEP, BASE SECTION (1) CORE MTD.
6. 11" x 11" DUCTED K.O. x 13 1/2" DEEP, DRAFT: T=6", S1=5", S2=5", B=0", INT. SECT. (2) CORE MTD.
7. 8" x 16" K.O. x 3" DEEP, DRAFT: T=2", S1=2", S2=2", B=0", INT. SECT. (4) CORE MTD.
8. 7/8" DIA. x 9" GALVANIZED PULL IRON, BASE SECTION (2) CORE MTD.
10. 1/2" P-36-T INSERT, TOP SECTION (2) SHELL MTD.
11. 1/2" PLASTIC INSERT, INT. SECT. (4) CORE MTD.
12. 1/2" P-35-T O.B. INSERT W/CLEAN-OUT HOLE, TOP SECTION (4) FRAME MTD.

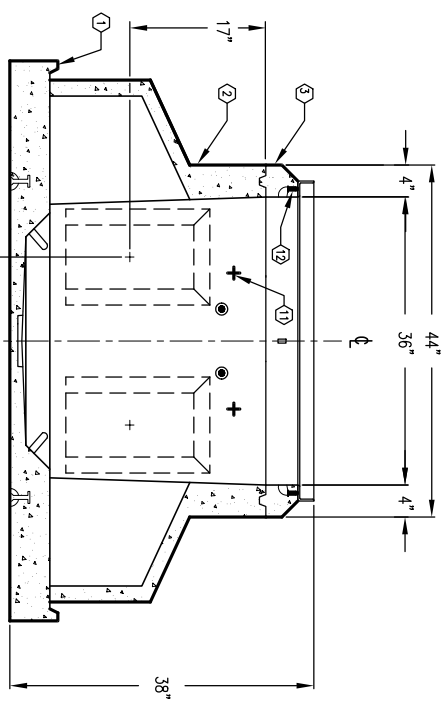

SECTION A-A

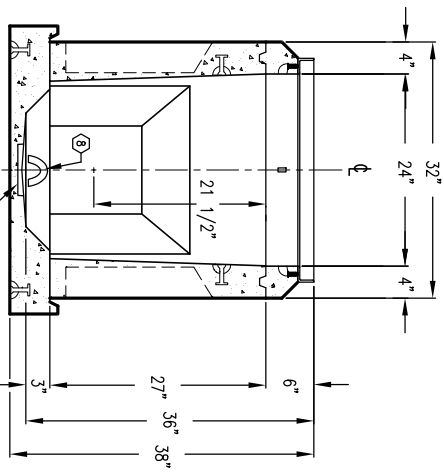

SECTION B-B

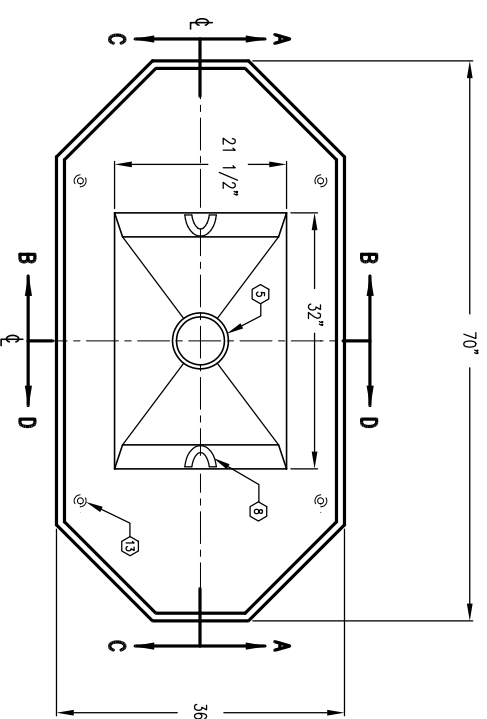

PLAN VIEW BOTTOM SECTION

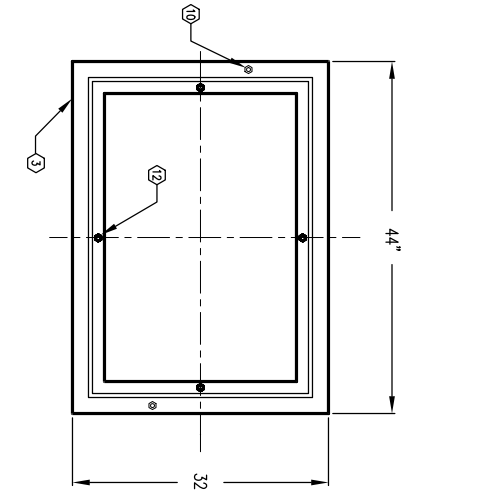

PLAN VIEW TOP SECTION

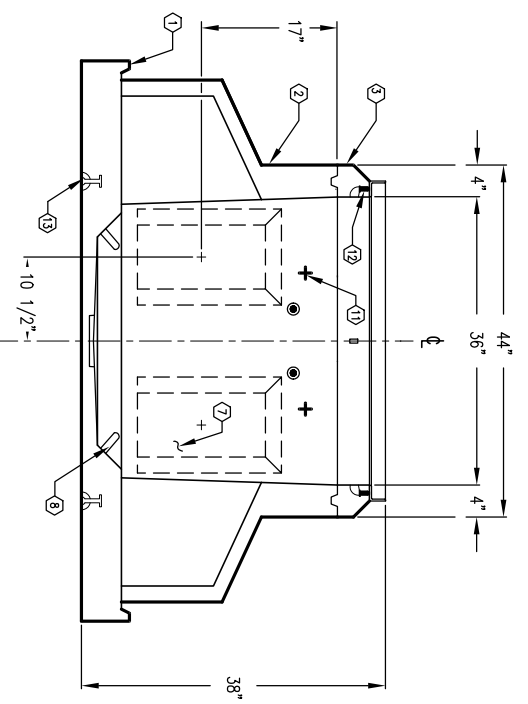

SECTION C-C

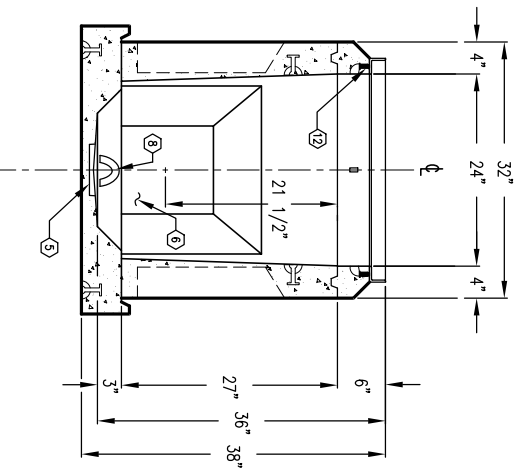

SECTION D-D



K2436-DI36-12P

PER LADWP SPEC. E-541 G-1
03-01-02



K2436-DI36-12P

PER LADWP SPEC. E-541 G-1
03-01-02

#	DATE	DESCRIPTION	BY