

# 2'-6" x 4'-0" LADWP TRAFFIC INTERCEPT BOX x 36" DEEP

**NOTES:**

- INTERCEPT BOX DESIGNED IN ACCORDANCE WITH AASHTO H-20-44 TRAFFIC BRIDGE LOADING USING 5,500 PSI COMPRESSIVE STRENGTH CONCRETE AND 60,000 PSI YIELD STRENGTH ASTM A-706 STEEL REINFORCEMENT PER CALC. #31639.
  - COVER DESIGNED FOR H-20-44 TRAFFIC LOADING FOR USE IN OFF-STREET LOCATIONS PER CALC. #31645.
  - INTERCEPT BOX TO BE PLACED ON A MIN. 6" BASE OF CRUSHER RUN FOR EASE OF INSTALLATION AND END LOAD DISTRIBUTION.
  - CONCRETE MIX USED IN POURING THIS PRODUCT SHALL USE FLY-ASH AS AN ADMIXTURE.
  - EACH CONCRETE SECTION SHALL BE MARKED ON THE INSIDE & OUTSIDE WITH "JENSEN PRECAST", THE DESIGNATION "DWP/FA", AND THE DATE OF POUR.
  - EACH CONCRETE SECTION SHALL HAVE CAST-IN ON THE INSIDE "JENSEN", THE YEAR, AND THE DESIGNATION "FA".
- ORDERING INFORMATION:**
- K3048-DI36-12T FOR ASSEMBLY AS SHOWN.  
TOTAL WEIGHT OF ASSEMBLY SHOWN IS 3,406#.
- GENERAL NOTES:**
1. Minimum soil bearing capacity is hereby assumed to be 2000 PSF unless otherwise documented by a geotechnical report that shall be provided to Jensen Precast by the end user. Jensen Precast shall not be held responsible for the soil bearing capacity.
  2. Installation of Manholes, Vaults, Handholes, Meter Boxes etc. will be as per Jensen installation procedures.
  3. Structural modification to the Jensen line of products is not permitted without prior written approval from Jensen Engineering Department.
  4. Do not scale the drawings, verify all dimensions including rough openings, if any discrepancies are found, notify the Jensen Engineer immediately.
  5. The Jensen Engineer will interpret the intent of the drawings in case of possible conflict or discrepancy.
  6. Permissible Variations:
    - Dimensional Tolerances – The length, width, height, or dia. measurements of the structure when measured on the inside surfaces shall not deviate from design dimensions by more than the following:
      - Dimensions: 0 to 5 Feet 1/4"
      - 5 to 10 Feet 3/8"
      - 10 to 20 Feet as agreed upon between the supplier and purchaser.
    - Squareness Tolerance: The inside of the precast concrete component shall be square as determined by diagonal measurements. The difference between such measurements shall not exceed the following:
      - Measured Length: Allowable Difference 0 to 10 Feet 1/2"
      - 10 to 20 Feet 3/4"
      - 20 Feet and over as agreed upon between the supplier and purchaser.

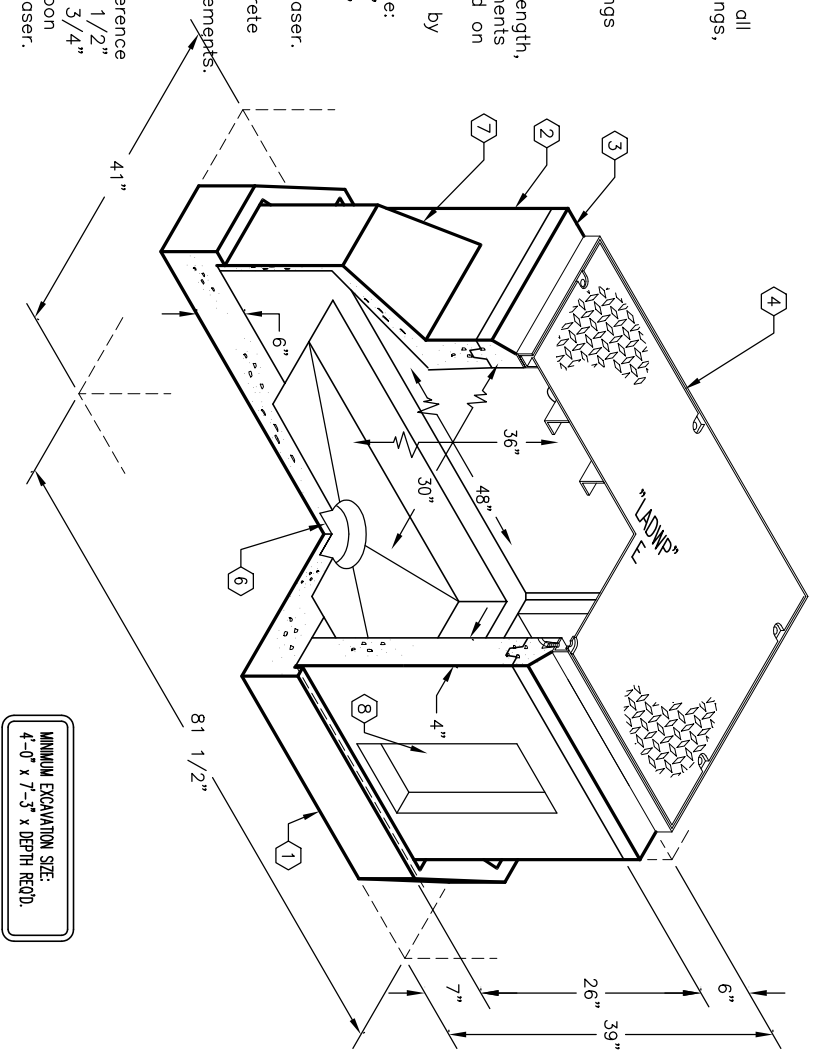

1. PB3048-B-12, BASE SLAB, WT. 1,700 Lbs.
2. PB3048D-127-12, INTERMEDIATE SECTION, WT. 1,223 Lbs.
3. PB3048-16-12, TOP SECTION W/F3048-PB-ANG GALV. ANGLE FRAME CAST IN WT. 213 Lbs.
4. SC3048-TSRGV-12, ONE PIECE TRAFFIC SLIP RESISTANT GALV. COVER, W/ (6) 1/2" x 13MC x 2 1/2" S.H.H.S.S. BOLTS, WT. 236 Lbs.
5. (2) 1" DIA. LIFTING HOLES, MARK "LADWP-E", WT. 236 Lbs.
6. 6" x 7" DIA. SUMP x 2" DEEP, LOCATE AS FOLLOWS: INT. FOLLOWS: BASE SLAB (1) TABLE MTD.
7. 14" x 14" DUCTED K.O. x 12" DEEP, DRAFT AS FOLLOWS: T=5", S1=S2=5", B=0". LOCATE AS FOLLOWS: INT. SECTION (2) CORE MTD.
8. 8" x 16" K.O. x 3" DEEP, DRAFT AS FOLLOWS: T=2", S1=1/2", S2=1/2", B=2". LOCATE AS FOLLOWS: INT. SECTION (2) CORE MTD.
9. 7/8" x 12" PULL IRON, LOCATE AS FOLLOWS: BASE SLAB (2) CORE MTD.
10. (2) 1/2" PLASTIC INSERTS, LOCATE AS FOLLOWS: INT. SECTION (12) CORE MTD.
11. (2) 1/2" P-35-T INSERTS W/CLEAN-OUT HOLES, LOCATE AS FOLLOWS: TOP SECTION (6) FRAME MTD.
12. (2) 1/2" P-36-T INSERTS, LOCATE AS FOLLOWS: TOP SECTION (2) SHELL MTD.

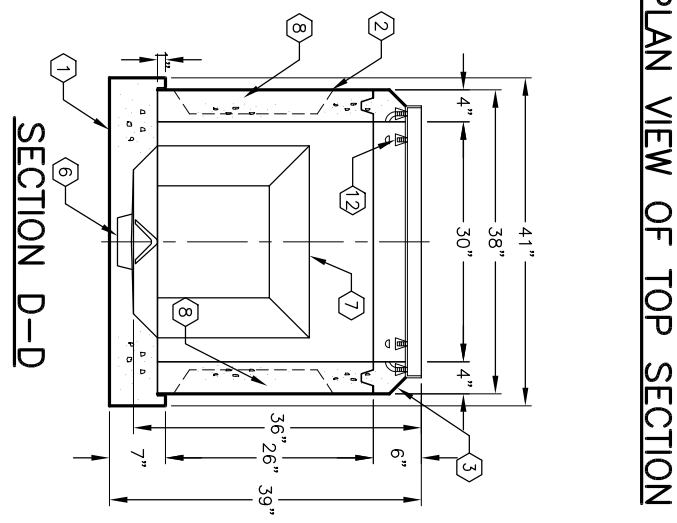
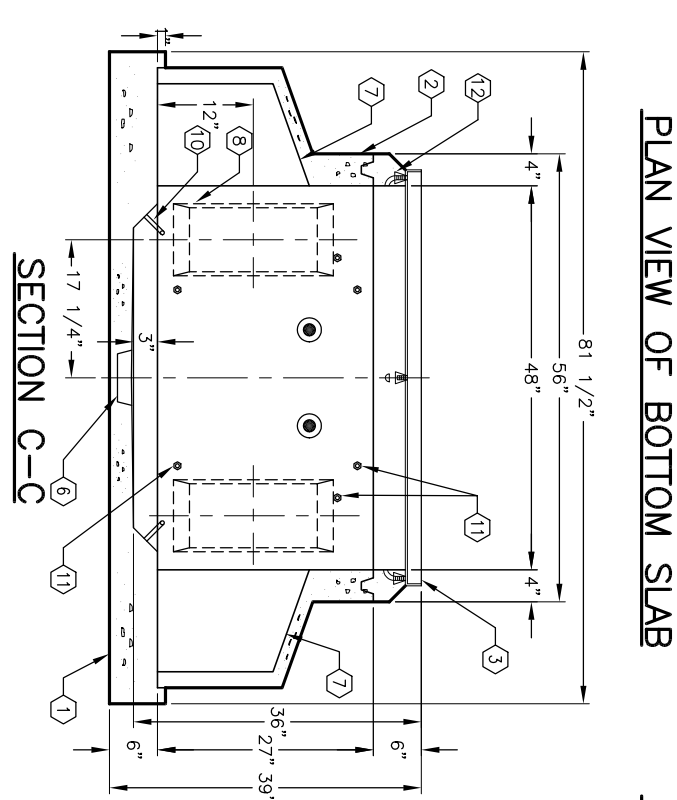
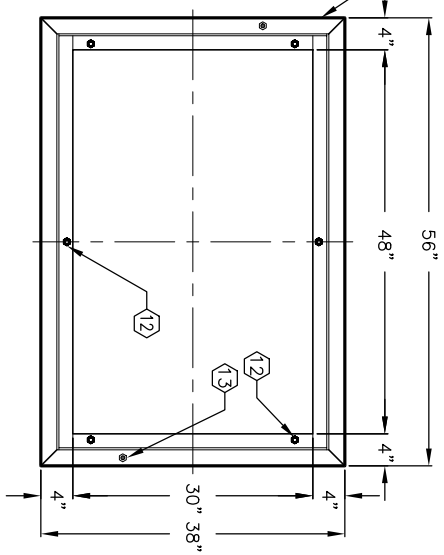
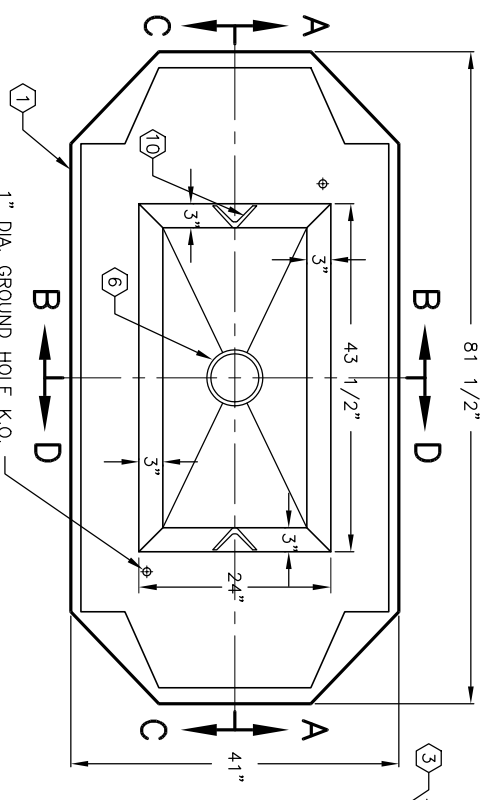
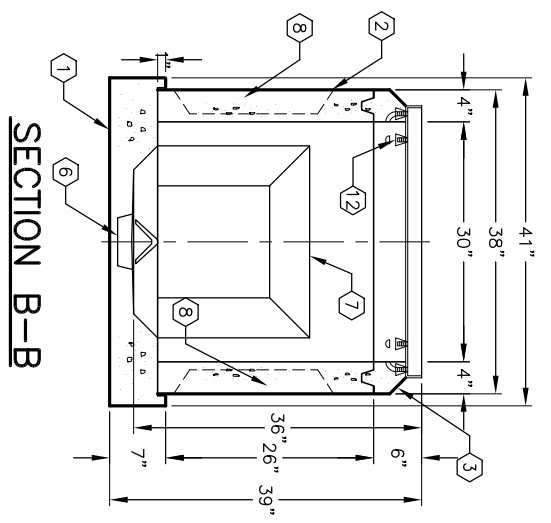
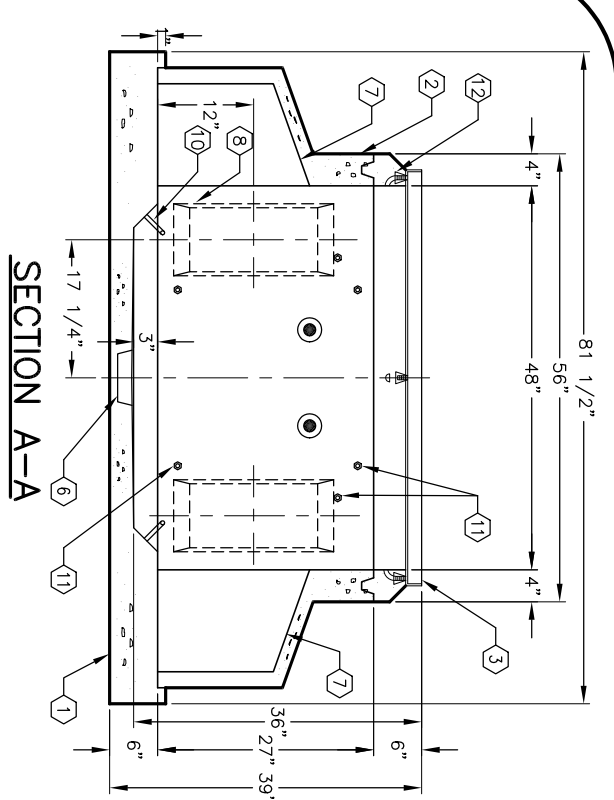

#	DATE	DESCRIPTION	BY